

CERN COURIER

International Journal of High Energy Physics

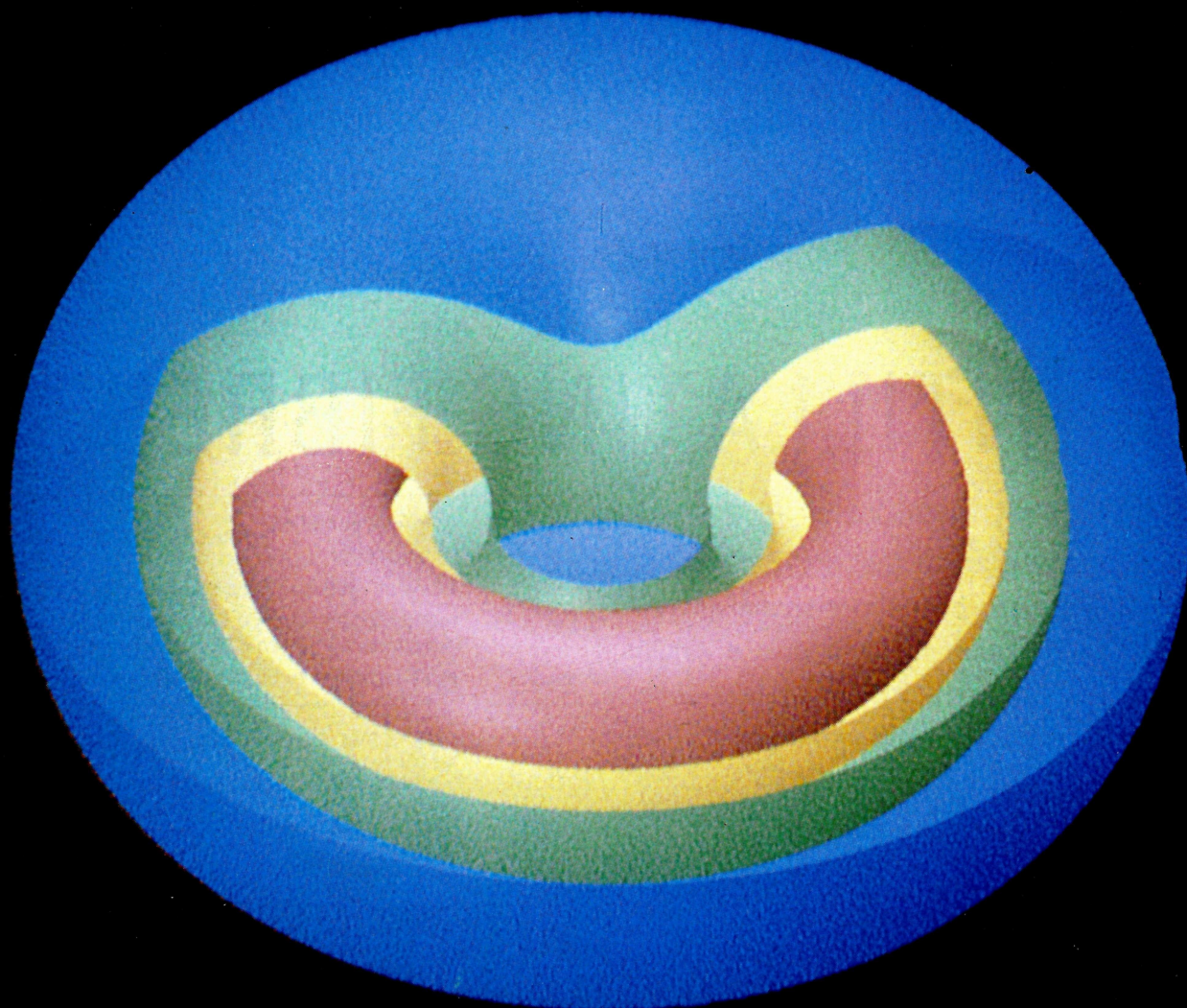

VOLUME 29

10

DECEMBER 1989

Laboratory correspondents :

Argonne National Laboratory, USA
M. Derrick
Brookhaven National Laboratory, USA
A. Stevens
CEBAF Laboratory, USA
S. Corneliussen
Cornell University, USA
D. G. Cassel
DESY Laboratory, Fed. Rep. of Germany
P. Waloschek
Fermi National Accelerator Laboratory, USA
M. Bodnarczyk
GSI Darmstadt, Fed. Rep. of Germany
G. Siegert
INFN, Italy
A. Pascolini
IHEP, Beijing, China
Wang Taijie
JINR Dubna, USSR
B. Starchenko
KEK National Laboratory, Japan
K. Kikuchi
Lawrence Berkeley Laboratory, USA
W. Carithers
Los Alamos National Laboratory, USA
O. B. van Dyck
NIKHEF Laboratory, Netherlands
F. Ern e
Novosibirsk Institute, USSR
V. Balakin
Orsay Laboratory, France
Anne-Marie Lutz
PSI Laboratory, Switzerland
J. F. Crawford
Rutherford Appleton Laboratory, UK
Louise Hall
Saclay Laboratory, France
Elisabeth Locci
IHEP, Serpukhov, USSR
Yu. Ryabov
Stanford Linear Accelerator Center, USA
M. Riordan
Superconducting Super Collider, USA
N. V. Baggett
TRIUMF Laboratory, Canada
M. K. Craddock

General distribution

Monika Wilson (MONIKA at CERNVM)*
CERN, 1211 Geneva 23, Switzerland

In certain countries, copies are available on request from:

China

Dr. Qian Ke-Qin
Institute of High Energy Physics
P.O. Box 918, Beijing,
People's Republic of China

Federal Republic of Germany

Gabriela Martens
DESY, Notkestr. 85, 2000 Hamburg 52

Italy

Mrs. Pieri or Mrs. Montanari
INFN, Casella Postale 56
00044 Frascati, Roma

United Kingdom

Su Rooke
Rutherford Appleton Laboratory,
Chilton, Didcot, Oxfordshire OX11 0QX

USA/Canada

Margaret Pearson (B90904 at FNALVM)
Fermilab, P.O. Box 500, Batavia
Illinois 60510

CERN COURIER is published ten times yearly in English and French editions. The views expressed in the Journal are not necessarily those of the CERN management

Printed by: Presses Centrales S.A.
1002 Lausanne, Switzerland

Published by :

European Laboratory for Particle Physics
CERN, 1211 Geneva 23, Switzerland
Tel. (022) 767 61 11, telex 419 000 CERN CH,
telex (022) 767 65 55
CERN COURIER only: tel. (022) 767 41 03,
telex (022) 782 19 06

USA : Controlled Circulation
Postage paid at Batavia, Illinois

Covering current developments in high energy physics and related fields worldwide

Editor: Gordon Fraser (COURIER at CERNVM)*
with Brian Southworth (SOUTHW at CERNVM)*
French edition: Henri-Luc Felder

Advertisements: Micheline Falciola (FAL at CERNVM)*

Advisory Panel: P. Darriulat (Chairman), H. B ggild,
H. Lengeler, A. Martin

* (Full electronic mail address... at CERNVM.CERN.CH)

1	LEP inauguration <i>World's largest scientific machine ceremonially launched</i>
1	The LHC road at CERN <i>Making the most of LEP</i>
4	Laying the keel <i>Preparing for US Supercollider</i>
9	Working with high collision rates <i>Detectors for the new colliders</i>
12	Stanford survives 7.1 shock <i>Earthquake!</i>
13	Applying the accelerator <i>Spinoff from particle physics</i>
17	Physics for KAON <i>Research possibilities for proposed Canadian facility</i>

Around the Laboratories

18	CERN: First physics from LEP/Trapped nuclides <i>Z particles in the spotlight/Low energy techniques in action</i>
20	YEREVAN: Acceleration workshop <i>Regional meeting</i>
20	FERMILAB: Physics in the 1990's <i>Looking to the future</i>
23	1989 Nobels
24	SERPUKHOV: Channeling <i>Crystals in particle beams</i>

24	People and things
----	--------------------------



Cover photograph:

A collaboration between IBM's UK Scientific Centre (providing the 3D computer graphics) and Oxford and Southampton Universities investigated the energy distribution around a pair of magnetic monopoles. At zero monopole separation, an axial rather than radial symmetry appears, due to non-linear interactions (Photo IBM UK Scientific Centre, Winchester).

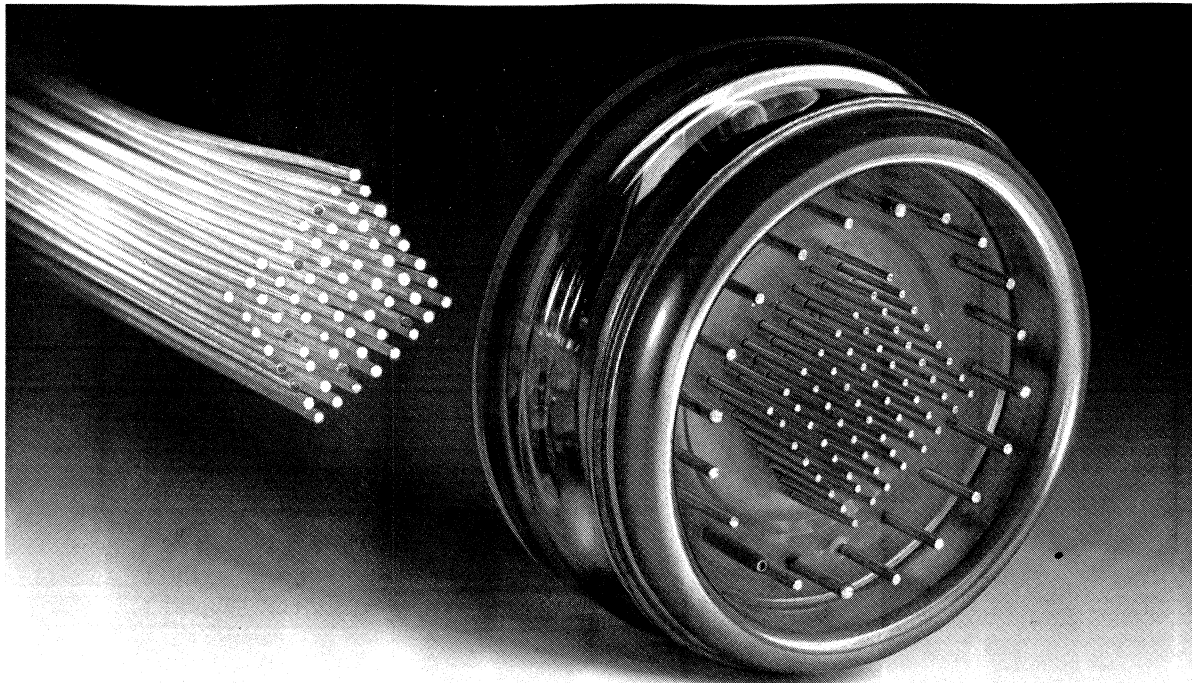

SCINTILLATING FIBRES?

XP4702 reads them out 64 at a time!

First of a new family, the XP4702 extends PMT talents into the realm of spatial as well as time resolution. Combined in a single envelope, 64 ten-stage multipliers with long-life CuBe dynodes produce an 8x8 mosaic of discrete pixels. With uniform channel-to-channel gain and transit-time. The common anode supplies an additional signal that can be used for amplitude analysis or triggering.

S_k (λ)	40 mA/W at 400 nm
G	10^6 at 1400 V
t_r	4.8 ns at 1400 V
output	segmented last dynode, 8x8 matrix of 64 independent 2.54 mm x 2.54 mm elements
crosstalk	<5% (scanned by 50 μ m light spot)

XP4702 opens new opportunities in fibre readout, hodoscopy, calorimetry and coarse imaging. Reference: NIM A269 (1988) 246-260.



Fibres courtesy of Optectron, France.

For more information contact: Philips Components, Building BAF2, 5600 MD Eindhoven, The Netherlands. Telex 35000 phtcn/nl jeveo.

STILL SETTING THE STANDARD

Philips Components



PHILIPS



A solid foundation for ISDN testing: Wandel & Goltermann

ISDN is the next step in the evolution of today's telephone and data networks. Since ISDN builds on the existing telecom and datacom networks, it makes sense to rely on the experience of a leader in the test and measurement field. For years network operators worldwide have counted on our level meters and data test equipment to keep their systems running. Wandel & Goltermann is now offering a complete line of ISDN test and measurement equipment. We can provide economical, custom test systems for your ISDN applications. Contact us for the best in ISDN test equipment.

Wandel & Goltermann (Schweiz) AG, Postfach 779
3018 Bern 18, Tel. 031-556544, Tlx. 9 12 350 wgch

- Please send information about your ISDN equipment
- Please arrange for a sales engineer to call

Name

Company

Street

Town

Telephone no. E 2.89/VMW/02/BW/CH

LEP Inauguration

First physics from LEP – see page 18

On 13 November, Heads of State, Heads of Government and Ministers from CERN's 14 Member States, together with more than a thousand invited guests, attended the inauguration ceremony of LEP, CERN's new 27-kilometre electron-positron collider. The event reflected CERN's pride in the construction and now extremely successful operation of the world's largest scientific machine and such a fine example of international collaboration. A full report on the event will feature in the next issue.

CERN Director General Carlo Rubbia addresses the LEP inauguration ceremony on 13 November. Speeches also came from King Carl XVI Gustaf of Sweden, President of the Swiss Confederation Jean-Pascal Delamuraz and French President François Mitterrand. The representatives of CERN's 14 Member States then symbolically signed a document 'opening up the era of scientific experimentation with the LEP collider'.

(Photo CERN)



The LHC road at CERN

Well before the successful completion of the LEP project at CERN, thinking on future options for the Laboratory had begun to take shape, being ultimately spear-headed by the Long Range Planning Committee chaired by Carlo Rubbia, now Director General.

To explore the 1 TeV (1000 GeV) energy scale where fundamental particle interactions should encounter new conditions, two major routes were proposed – a high magnetic field proton collider in the LEP tunnel, dubbed LHC for Large Hadron Collider, and the CERN Linear Collider (CLIC) to supply beams of electrons and positrons.

Two years down the line, exploratory studies have shown that while CLIC remains a valid long-term goal, LHC appears as the most cost-effective way for CERN to enter the 1 TeV arena. At these energies, the 'weak' nuclear force is expected to become powerful enough to match its electromagnetic partner, opening the door to the underlying symmetry breaking mechanism, thought to be due to a 'Higgs' particle (July/August page 1), which makes the two phenomena look so different at lower energies.

High-field superconducting magnet prototype work (September,

page 5) demonstrates that a 'two-in-one' design supplying the 10 tesla fields needed to handle LHC's 8 TeV proton beams (collision energy 16 TeV) is a practical proposition.

By compressing the colliding proton beams as tightly as possible, by increasing both the number of proton bunches and the number of protons in each bunch, LHC's design luminosity (a measure of the collision rate) has been uprated from the 1.4×10^{33} per sq cm per s level initially foreseen to as high as 4×10^{34} , providing a powerful lever arm for new physics.

The machine energy is optimal to explore the 100 – 1000 GeV energy domain where new phenomena should shed light on the origin of mass in the electroweak picture, where the steady upward path of mass limits for the so far unseen sixth ('top') quark has led to a rethink on the expected decay patterns of the Higgs. The missing particle could be picked up through a characteristic decay into two Z particles, giving a readily detectable signature. While such a search would exploit to the full LHC's high collision rate, less rare phenomena could be studied at lower luminosity beam crossing points.

As well as being well suited to this emerging pattern of physics at the new energy frontiers, LHC also capitalizes on both the LEP tunnel and CERN's unrivalled expertise in proton accelerator know-how. LHC has other trump cards too. Able to handle heavy ions as well as protons, LHC would provide a new arena to explore very high concentrations of nuclear energy, recreating more vividly the conditions of the 'Big Bang' which spawned the Universe. With LHC's proton rings rubbing shoulders with LEP, a new energy range for electron-proton collisions would open up, extending the pioneer studies shortly to begin at the new HERA collider at the German DESY Laboratory in Hamburg.

Although its tunnel is ready and waiting, LHC would cost about as much as LEP itself, the price tag being dominated by the state-of-the-art superconducting magnets.

Research and development work for these magnets is well advanced, with firms and research Laboratories in Austria, Belgium, France, Germany, Italy, the Netherlands, Spain, Switzerland and the United Kingdom involved. CERN's

master plan foresees production of series magnets getting underway in 1992, with the machine being commissioned in 1996-7.

The coming year will see the refinement of ongoing R and D work and its extension into the detector technology sector to meet the stringent demands of the LHC environment, particularly for fast electronics and on-line data processing (see page 9). In parallel, the ma-

chine design will be optimized through close dialogue between accelerator physicists and experimenters.

An artist's impression of the LHC superconducting proton collider ring installed above the existing LEP electron-positron collider.

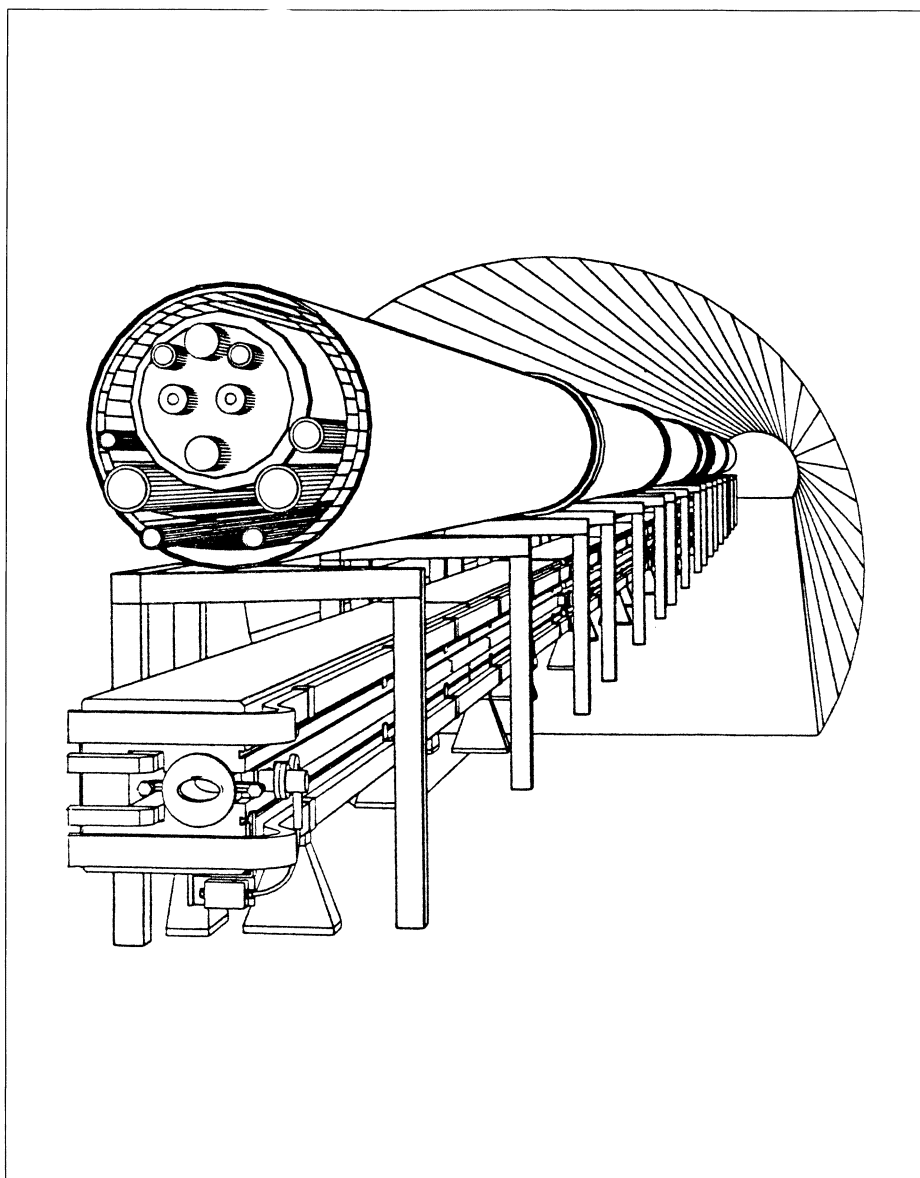

R max. 1500 mm

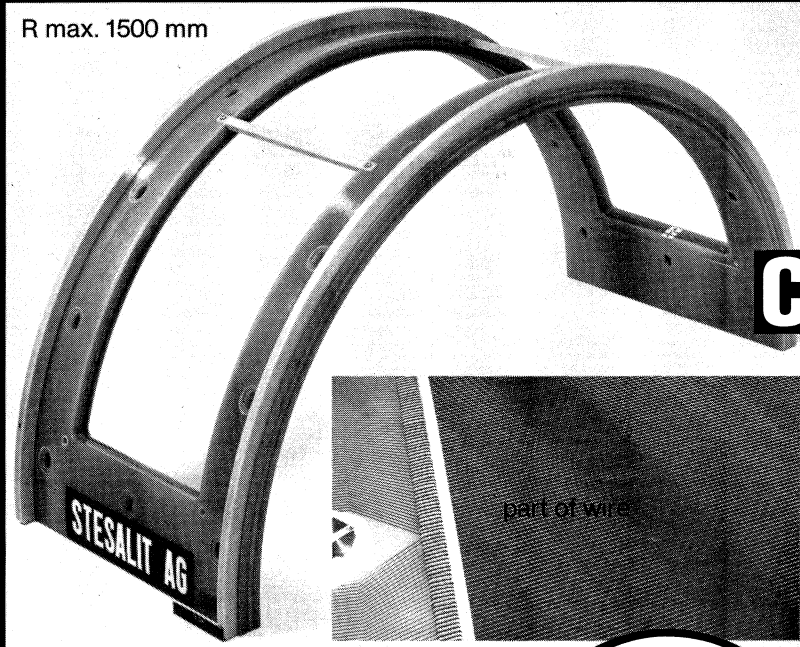

Semicircular, 8-Piece CERN Chamber,

manufactured rigid, with bonded plate-bars.

Please request detailed information. Mr H. Mauch will be glad to advise you personally.

We offer a range that is based on 30 years' experience and know how through successful collaboration with field specialists.

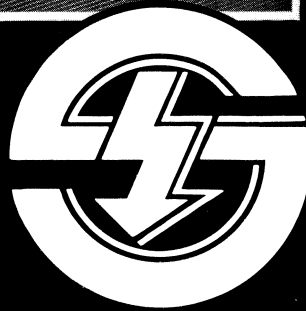

Stesalit AG Kunststoffwerk

We provide easily built-in safety in Know-how.

CH-4234 Zullwil SO Telefax 061/80 06 04
Telephone 061/80 06 01 Telex 963 182

***Probably the best
current transducer
you can buy...***

Features of the ULTRASTAB® Current Transducer:

- Max. current ranges 600 or 2000 Amps
- Programable from 40 to 2000 Amps
- Low feed back noise – down to 2 μ V
- Low output noise – down to 0.1 ppm
- Low temperature coefficient – down to 0.1 ppm/°C
- High linearity – up to 2 ppm
- Wide frequency bandwidth – DC to 500 kHz



DANFYSIK A/S – DK-4040 Jyllinge
Denmark
Tel.: +45 42 38 81 50
Fax: +45 42 13 15 51
Telex: 43 136

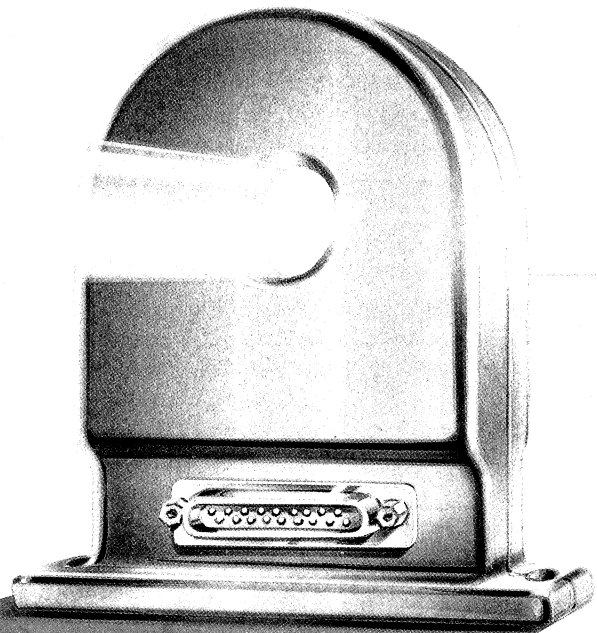

Laying the keel

The start of construction of the 87-kilometre US Superconducting Supercollider (SSC) was celebrated in Dallas at the beginning of October with a Texas-style meeting on SSC physics and experiments. Chris Quigg described it as 'laying the keel of a new vessel of discovery'. The vessel is scheduled to make its maiden voyage with 20 TeV (20,000 GeV) proton beams in 1998.

In fiscal year 1990, which began on 1 October, \$135 million out of \$225 million for the SSC project is allocated to the start of construction. The State of Texas has pledged a further \$90 million for the same year, much of which will be used for the first buildings on the Laboratory site in Ellis County.

The precise location of the Collider and the Laboratory campus areas (known as the SSC 'footprint') has been decided and acquisition of the land is starting. Over 400 have already joined the staff of the new Laboratory and the complement will rise to over a thousand in the coming year.

There is great excitement in the US particle physics community at the start of SSC construction, which will open up the behaviour of the constituent particles of matter at the TeV (1000 GeV) energy scale.

At these TeV energies the electromagnetic and 'weak' nuclear forces become of comparable strength, and the underlying 'symmetry breaking' mechanism, responsible for the different behaviour of the two forces at lower energies, should be revealed.

This symmetry breaking provides particle masses – the photon carrier of the electromagnetic force having no mass while the W and Z carriers of the weak force are very heavy. The favoured theoretical

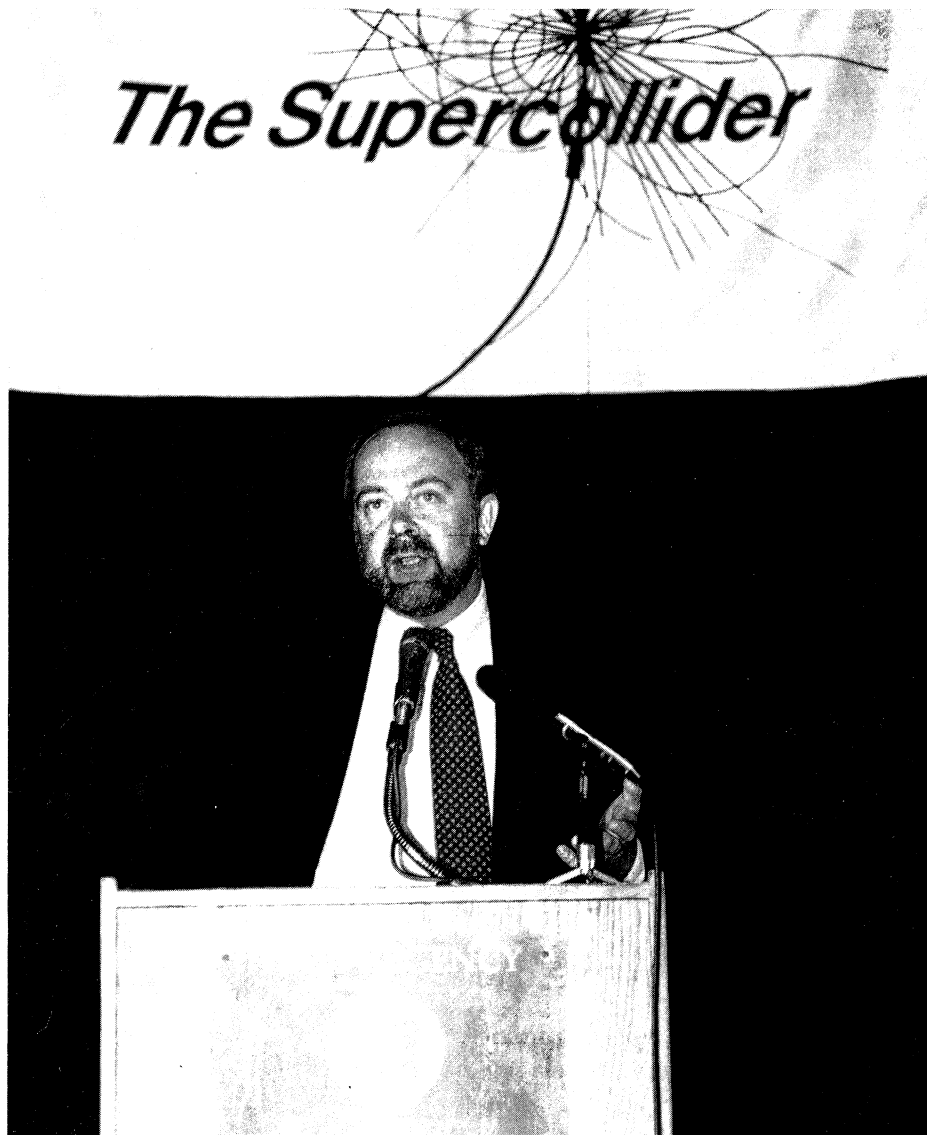

'Things are going tremendously well' ... Roy Schwitters, Director of the SSC Laboratory, speaking at the Dallas meeting in October as the 87-kilometre Collider moves into its construction phase.

(Photos SSC, Cliff Roe)

mechanism involves one or more 'Higgs' particles (July/August, page 1). Higgs particles should be found at the 1 TeV mass region or (even more intriguingly) some alternative phenomenon should appear.

Of course the electroweak symmetry breaking and the Higgs mechanism are not the only physics questions which can be addressed at the SSC or the proposed Large Hadron Collider at CERN (see page 1). The colliding proton beams will probe distances down to 10^{-17} cm and will recreate conditions 10^{-14} second into the 'Big Bang' creation of the Universe. Steve Weinberg maintained 'the funding of the SSC guarantees that the wonderful story of our understanding of nature has not come to an end'.

Evolving the experimental programme

Thinking about how to explore the physics potential opened up by the SSC has been underway ever since the project was first mooted in 1982. Schematic detector designs by informal collaborations, both for general purpose and specialized experiments, have identified the many areas of detector technology where abilities have to be extended to cope with the energies and rates which will be experienced at the new machine. A range of physics interests and detector possibilities were presented in sessions organized by the Users Organization for the SSC (UOSSC).

General-purpose schemes include SDE (Solenoid Detector Experiment), FAST (Fibre and Scintillator Technology), L* (building on the L3 experience at LEP), and two ideas under study in Japan – ACS

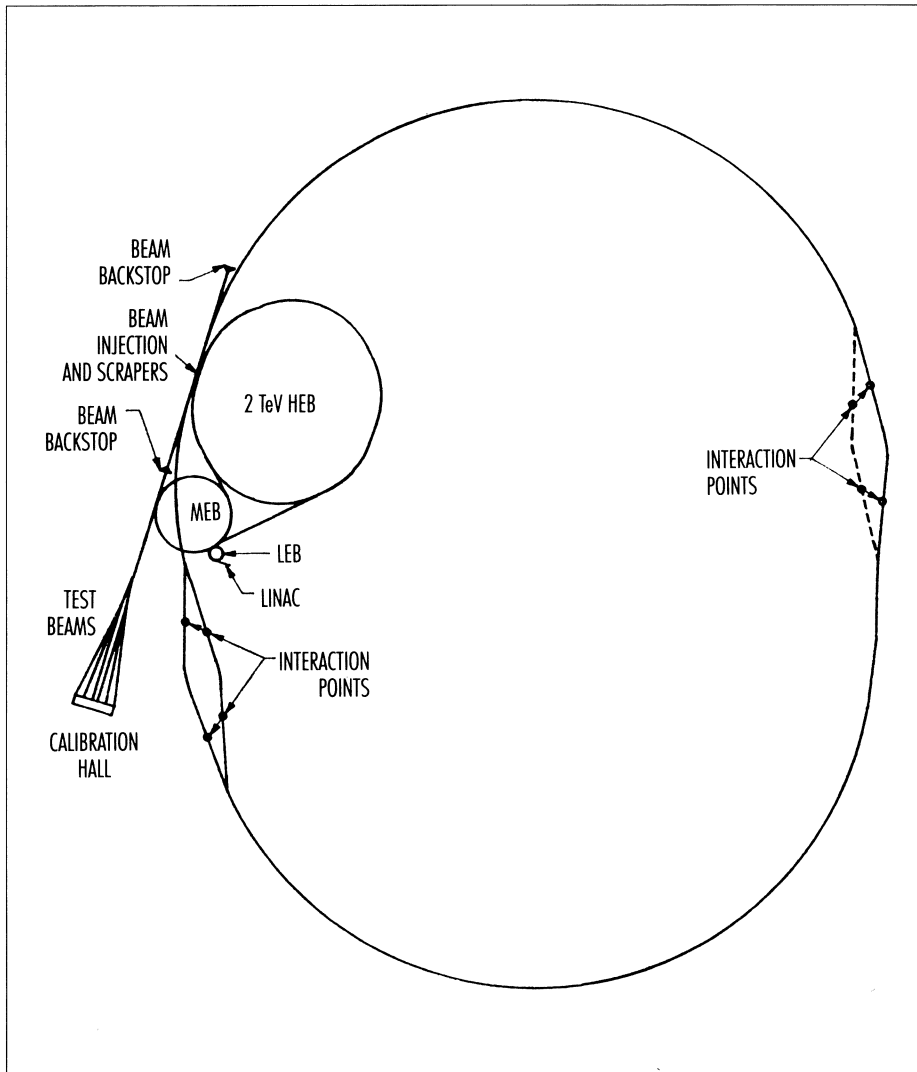

A schematic of the SSC (not to scale) incorporating recent design changes. The sequence now goes: 600 to 1000 MeV negative hydrogen ion linac, 10 GeV low energy booster (LEB), 200 GeV medium energy booster (MEB), 2 TeV superconducting high-energy booster (HEB), 20 TeV Collider 87 kilometres in circumference.

Injection of the counter-rotating proton beams into the Collider is presently planned by inverting the polarity of the superconducting magnets in the HEB. The linac, LEB and MEB will be built on the surface while the HEB and the Collider will be underground. The diamond-shaped bypass configuration of the interaction regions allows an eventual total of eight collision regions for experiments; a ninth could be added diametrically opposed to the injection point.

ters for subsequent Laboratory support en route to the preparation of full proposals by late 1991.

Final approval will follow traditional ICFA guidelines on experimental programmes, in keeping with the SSCL's commitment to being a Laboratory for international science, and will be based on scientific merit, the quality of the proposing collaboration, and the technical and financial viability of the proposal.

The Collider design

A number of changes are being studied in moving from the Conceptual Design Report, worked out by the team led by Maury Tigner, to the design specific to the Ellis County site. There is also fresh input from the Laboratory team which will build the machine. Quite a number of machine parameters remain to be decided, which hinders detailed costing and scheduling.

In response to concern about the effects of persistent currents in the superconducting magnets at low fields, when the protons have to be held for some time during beam injection, the injection energy into the Collider will probably be in-

(Air Cored Solenoid) and HCD (Hermetic Collider Detector). More specific studies could be confronted with EMPACT (a non-magnetic detector), BCD (Bottom Collider Detector for a thorough study of CP violation in beauty-pair production) and FTD (Fast Triggering Detector) evolving from experience at Fermilab.

A detector research and development programme, guided by an international advisory committee chaired by H.H. Williams, has been underway for the past two years to confront the problems of very high radiation environments, high event rates and very low signal-to-noise ratios. Silicon detectors, new scintillators, liquid calorimeters, large superconducting magnets, readout mechanisms, parallel processing, data recording systems, etc ... are under development (though more funds may be needed to push these programmes).

The Laboratory is already preparing for selection of the first round of experiments because of

the long lead-time in designing and building the huge detectors to be ready for first collisions in 1998. The selection will also be important input for collider construction with the building of the detector halls and decisions on test beams. It is hoped to have a broad programme in place for start-up of the machine, with at least one general purpose detector and some specialized detectors. A bypass configuration of the collision regions will allow staging of the detectors, so that assembly or upgrading could continue without interfering with collider operation.

The particle physics community has been invited to put forward 'Expressions of Interest' for SSC experiments by 25 May next. The format should be somewhere between the traditional short 'Letter of Intent' and a formal proposal. They will be reviewed by a newly-formed Program Advisory Committee, chaired by Jack Sandweiss, which will make recommendations to Laboratory Director Roy Schwit-

RENOVA LIBRIS

S. à R. L.

RELIURE ARTISANALE
DORURE
ENCADREMENTS
ARTICLES PUBLICITAIRES

Franz KATHARI, maître-relieur
Tél. (022) 41 10 15

5, chemin des Coquelicots
1214 Vernier-Genève

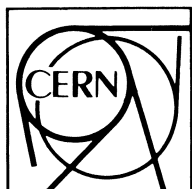

How to visit CERN

Comment visiter le CERN

Organized visits take place only on Saturdays, at 9.30 a.m., and/or 2.30 p.m. The visits last about three hours and are free. The minimum age limit is 16 years.

Les visites commentées ont lieu seulement le samedi à 9 h. 30 et/ou 14 h. 30. Elles durent environ trois heures et sont gratuites. La limite d'âge minimum imposée est de seize ans.

Please write or call:
Ecrire ou téléphoner:

CERN
Visits Organization / Organisation des visites
1211 GENEVA 23 Switzerland
Tel. 022/767 40 52 or/ou 767 41 02
Telex 419 000 CER

creased to 2 TeV. This followed another manoeuvre with the same purpose – a reduction in half-cell length of the magnet lattice from 115 to 90 m with a new correction magnet scheme should improve beam dynamics at injection energy. An increase in beam aperture from 4 to 5 cm could also help, but sophisticated calculations of beam loss over millions of turns are underway to judge whether this is really necessary.

Diamond-shaped collision regions will make it possible to decouple the detectors from the machine (with the philosophy that it is easier to move the beams than the detectors). Following adjustment of beam switching to direct the protons along the other arm of the diamond, detector construction, maintenance and upgrading could proceed without interfering with machine operation.

More extensive test beam facilities are to be built, receiving protons from both the 200 GeV and the 2 TeV booster injectors.

Care is being taken not to close the door to possible future upgrades of the machine such as luminosity increases beyond the design 10^{33} per sq cm per s, ejection of 20 TeV beams, internal targets, polarized proton beams, experiments at the 2 TeV booster, electron-proton collisions ... but these will not be built into the 'baseline design' and cost estimates.

Crucial components of the Collider are the 8000 superconducting dipoles. These magnets are not yet mastered. On the positive side, since the start of the magnet R and D programme four years ago, the performance of the conductor has improved dramatically and the magnets will easily give the 6.6 T field for 20 TeV operation. (Some work is continuing on conductor

improvement by further reducing superconducting filament sizes.) The magnets have been demonstrated to be mechanically sound, operating below 4.3 K, producing fields well above 6.6 T, and tolerating greater mechanical forces than at 20 TeV without any problems.

However there is still little knowledge about field characteristics and little data from the full-scale magnets on the problem of persistent currents. The very high standards of reproducibility and reliability required for 8000 magnets are still to be demonstrated. It is planned to build further full-scale magnets at the rate of fifteen per year before launching into industrial production three years from now.

Support from Texas

The Texas National Research Laboratory Commission has assigned some \$700 million (from its total of \$1 billion support of the SSC) for civil construction and will finance the building of a magnet development and testing facility next year. It is likely to be located near Waxahachie at the centre of the future Collider ring. The Commission will also finance construction of the central complex on the 'west campus' where the injection system is to be located. Construction of these buildings is scheduled to start early in 1991.

Texan support (about \$175 million) is also earmarked for electrical utilities which will bring SSC power costs to one cent or less per kWh; at this very low price the SSC should be able to operate year-round without straining the budget. The remaining Texan contribution will go into nationwide research projects related to the SSC. A start

has been made with the launching of an SSC Fellowship Programme to support twelve young scientists each year in science or technology projects related to the SSC.

The exceptional commitment of the State of Texas to the SSC is in evidence everywhere – from the declarations and lobbying of its most senior representatives, to the large financial support, down to the everyday detail of smoothing the way to bring the Laboratory into being. Behind the support there is an expressed belief in the value of pure research and the value of science education. In the welcoming address at the meeting, Judge Lee Jackson of Dallas County pointed out our understanding and admiration of those who climb Everest 'because it is there'. 'We ought to generate that sort of feeling about pure science,' he added.

The potential of the SSC in stimulating interest in science is among the central aims of the Laboratory:

- to create a premier international physics Laboratory by the year 2000;
- to create a major resource for science education;
- to create a Laboratory whose activities are carried out in a safe, responsible and environmentally sound manner that respects human rights and individual dignity.

Roy Schwitters brought the meeting to a close by inviting all participants to an international conference to be held in Dallas in 1999 featuring the first SSC physics results .

By Brian Southworth

CERN COURIER

A unique advertising medium for scientific and technical equipment

CERN COURIER is the internationally recognized news magazine of high energy physics. Distributed to all the major Laboratories of the world active in this dynamic field of fundamental research, it is compulsive reading for scientists, engineers, administrators, information media and buyers. Written in simple language and published simultaneously in English and French it has become the natural communication medium for particle physicists in Europe, the USA, the Soviet Union, Japan—everywhere where the fundamental nature of matter is studied.

Published from CERN, Switzerland, it also has correspondents in the Laboratories of Argonne; Berkeley, Brookhaven, Cornell, Fermi, Los Alamos and Stanford in the USA, Darmstadt, DESY and Karlsruhe in Germany, Orsay and Saclay in France, Frascati in Italy, Rutherford in the U.K., PSI in Switzerland, Serpukhov, Dubna and Novosibirsk in the USSR, KEK in Japan, TRIUMF in Canada and Beijing in China.

The annual expenditure on high energy physics in Europe is about 1600 million Swiss francs. The expenditure in the USA is about \$ 800 million. There is also considerable expenditure in the Soviet Union.

CERN COURIER is the way into all high energy physics research Laboratories. If you have a market in this field, there is no surer way to make your products known than by advertising in CERN COURIER.

All enquiries to:
Advertising Manager
Micheline Falciola
CERN COURIER
CERN
CH-1211 GENEVA 23
Tel. (022) 767 41 03
Telex 419 000 CER
Telefax (022) 782 19 06

Advertisements in CERN COURIER

Format A4

Monthly publication

All advertisements are published in both English and French editions. Second language versions accepted without extra charge.

Space (page)	Actual size (mm) width by height	Cost per insertion (Swiss Francs)			
		1 insertion	3 insertions	5 insertions	10 insertions
¹ / ₁	185 x 265 185 x 130	1980	1900	1830	1730
¹ / ₂	90 x 265	1170	1100	1040	960
¹ / ₄	90 x 130	690	630	590	550

These prices include no entitlement to special placing.

Supplement for:

— one additional colour 1500 SwF

— Covers:

Covers 2 and 3 (one colour) 2000 SwF

Cover 4 (one colour) 2500 SwF

Publication date 1st of month of cover date

Closing date for

positive films and copy 1st of month preceding cover date

The cost of making films and of translation for advertisements are charged in addition.

Screen (offset)

60 or 54 Swiss (150 English)

Advertisements cancelled after 1st of month preceding cover date will be invoiced.

These rates are effective for the year 1990.

All enquiries to:

Micheline FALCIOLA / CERN COURIER – CERN
CH-1211 Geneva 23 Switzerland

Telephone:
(022) 767 41 03

Telex 419 000 CER CH
Telefax (022) 782 19 06

Entreprise leader
en protection anticorrosion sur
structures métalliques et béton,
PREZIOSO est présente
partout en France

*PREZIOSO travaille au CERN
depuis 1967
et a exécuté
les travaux de peinture
et revêtements spéciaux
pour le LEP*

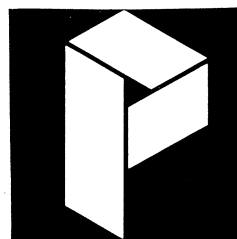

PREZIOSO

B.P. N° 2
38370 SAINT-CLAIR-DU-RHÔNE
Tél. (33) 74 56 42 28
Fax (33) 74 56 37 59

Working with high collision rates

In its role of monitoring the evolution of particle physics, anticipating needs for new accelerators, and stimulating the development of suitable instrumentation to exploit these new facilities, the European Committee for Future Accelerators (ECFA, appointed by the community of CERN Member States) has recently organized a series of workshops on the possible long-term projects for CERN (see page 1).

With the LHC proton collider for the LEP tunnel emerging as the main contender for immediate consideration, the main aim of a recent ECFA Study Week on 'Instrumentation Technology for High Luminosity Hadron Colliders' was to review progress and to critically evaluate candidate detection techniques and data handling methods for the very high collision rates foreseen for LHC, with luminosities exceeding 10^{34} per sq cm per s.

The Study Week was held at Universitat Autònoma in Barcelona from 14-21 September with sponsorship from the university, the CI-CYT of Spain, CERN and the Commission of the European Communities. It had attracted 220 participants including 35 from industry, and good representation from groups planning experiments at the US Superconducting Supercollider (SSC).

The meeting began with a survey of all hadron collider projects approved or under discussion. High energy proton designs now have to take account of synchrotron radiation, hitherto the concern only of electron machine builders. From the presentation of G. Brianti, it is clear that CERN has done its LHC homework and is ready for a project definition.

I. Hincliffe underlined physics issues and the energy-luminosity trade-off. Related detector require-

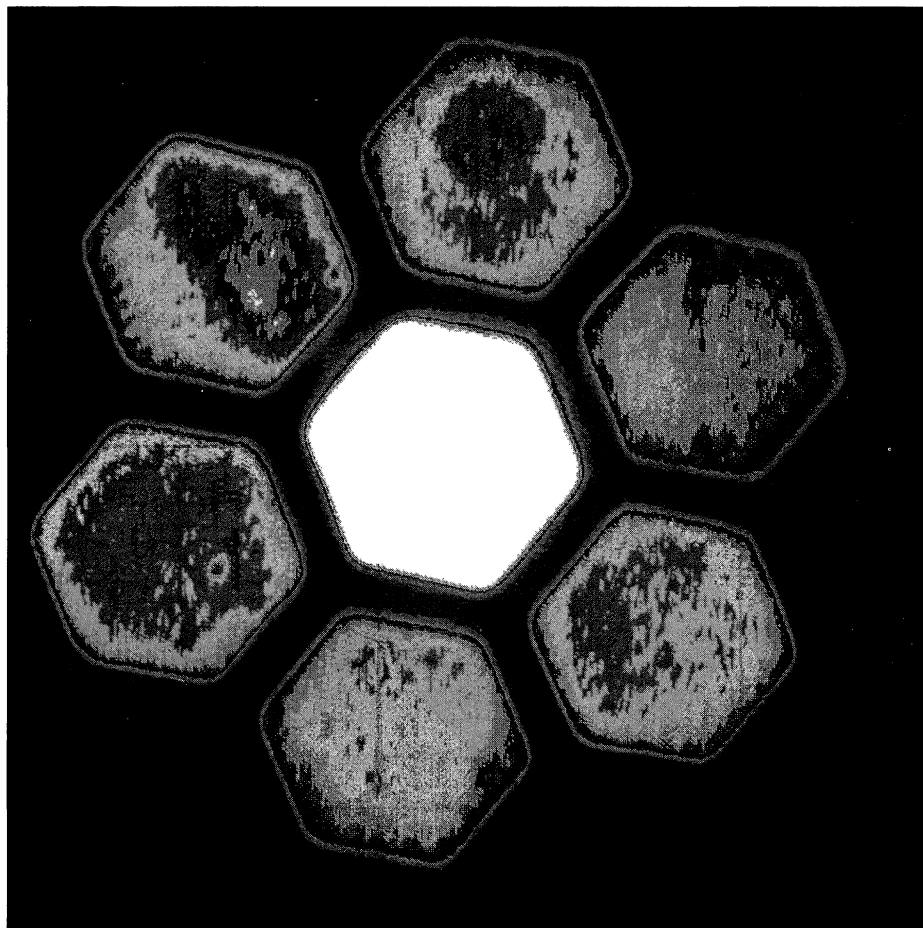

ments were reviewed by P. Jenni (calorimetry) and D. Saxon (tracking). The UA2 calorimetry experience is promising, however vertex measurements for an event-by-event identification of such processes as heavy quark production appears to be very difficult.

Illustrating SSC preparations, B. Pope and N. Di Giacomo covered the EMPACT (air core toroid) detector, where industry is already involved. S. Ting sketched how one of the LEP detectors might be adapted for LHC running.

Sessions covered the whole spectrum of instrumentation. Scintillating fibres are looking good, having proved their worth in the UA2 experiment at CERN's proton-antiproton collider for tracking and

Scintillating fibres are the subject of increasing attention in the search for new detector techniques. This CCD microphotograph shows a bundle of 30-micron diameter fibres with only the central fibre illuminated and low intensity scattered light in the neighbouring fibres. Part of the Italian-funded LAA scheme, this development work aims at precision particle tracking. Pioneer work in the use of fibres for tracking was carried out at the UA2 experiment at CERN's proton-antiproton collider (June 1987, page 9).

in a preconverter to an electromagnetic calorimeter. R&D on scintillating fibres is one of the main lines of the Italian-funded LAA project at CERN. PMP has been successfully explored as a fibre dopant. 3HF fibres appear sufficiently radiation-resistant for LHC central tracking and calorimetry. Very thin fibres are now available in multibundles

- For research · development · industry
- Voltages up to 500 kV
- Line/load regulation up to 10^{-6}
- Remote control analogous/IEC-bus
- Polarity reversible
- Bipolar
- Switchmode regulator
- Capacitor charging

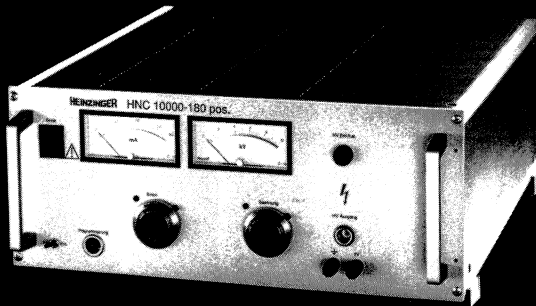

We supply not only high voltage!
Ask for our catalog.

HIGH VOLTAGE POWER SUPPLIES

HEINZINGER electronic GmbH
Anton-Jakob-Straße 4 · Postfach 180
D-8200 Rosenheim · Tel. 080 31/4404-0
Fax 080 31/440444 · Telex 525 777 hemes d

Your partner
for customers specific
power supplies

HEINZINGER
electronic

Fast-response bipolar power from unregulated DC

Used for correction-element drive by SLAC, FERMI and Brookhaven

Output	Model 220	Model 232	Model 290
Voltage	0 - $\pm 160V$	0 - $\pm 160V$	0 - $\pm 160V$
Current	0 - $\pm 15A$	0 - $\pm 90A$	0 - $\pm 230A$
Ripple	0.3%	0.3%	0.3%
Stability	50 ppm/ $^{\circ}C$	50 ppm/ $^{\circ}C$	50 ppm/ $^{\circ}C$
Bandwidth			
Small sig.	5 kHz	15 kHz	5 kHz
Full power	2 kHz	4 kHz	3 kHz
Dissipation	100W	600W	1500W

Based on high efficiency PWM technology, power modules are parallelable for higher current. The 80 kHz switching frequency yields wide bandwidth; built-in filters remove output noise.

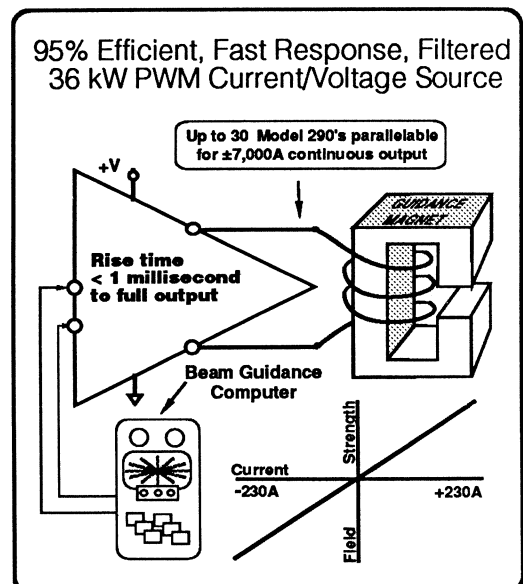

Copley Controls Corp., 375 Elliot St., Newton, MA 02164, USA

Telephone: 617-965-2410 FAX: (617) 965-7315 Telex: 285975

half a millimetre across from Kyoto in Japan. Dopant level can be adjusted to minimize crosstalk. The LAA group is investigating a promising idea where position as well as timing information can be preserved using a new type of delay tube attached to an image intensifier.

A lively session on silicon strip and pad detectors showed that development of more radiation-resistant silicon diodes and other structures is underway at several centres. A double-sided strip detector is being developed for the Aleph experiment at CERN, while silicon drift and pixel detectors are also progressing. Proposals have been tabled for SSC central tracking and some calorimetry using available silicon techniques. However it could be difficult to reconcile LHC's tight construction schedule with the relatively long factory turnaround times for new silicon or gallium arsenide solutions. Of particular interest is the construction of large integrated readout structures on the detectors themselves, for example using full wafers.

Traditional drift chamber structures are not suitable for LHC's high luminosity conditions, but F. Sauli's menu included maccheroni, cannelloni or fettuccine, all with attractive geometrical features including small drift distance and isolated anode readout where the death of a single cell is not a disaster. The 'fettuccine' design with strip electrodes deposited on a glass substrate looks especially interesting. Radiation damage is becoming better understood.

With no surfaces that can be damaged, recyclable liquids are good candidates for the difficult radiation conditions of forward detectors. The cheapest option, liquid argon, has relatively slow response requir-

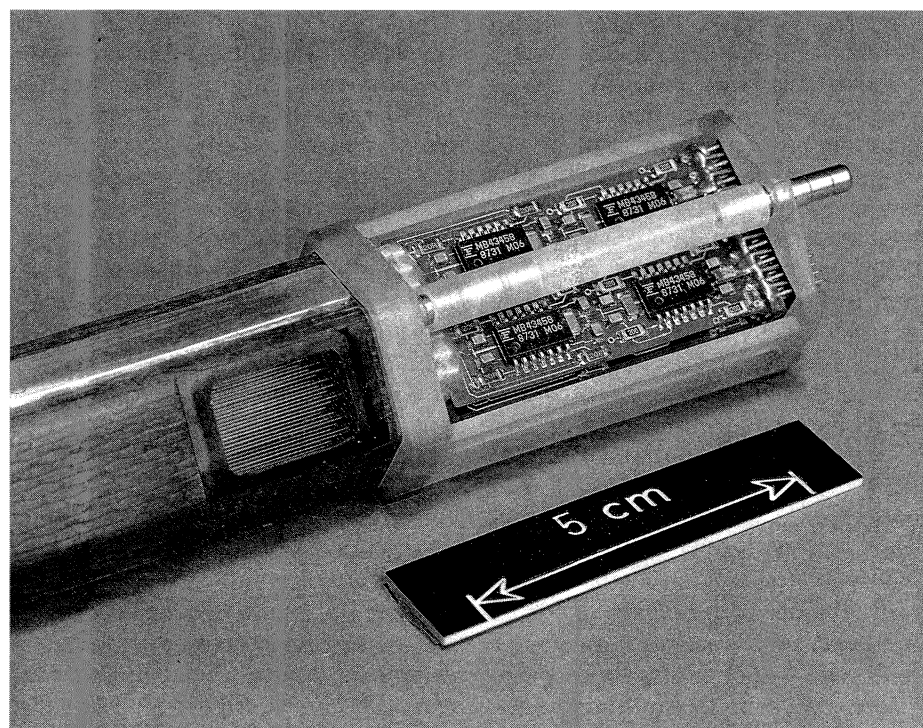

Prototype multi-drift module, also developed in the context of the LAA project, with a hundred independent drift cells, each 2.8 mm across, in a carbon fibre envelope, with high density electronics achieving comparable proportions. The window (for studying edge effects) is temporary, and would be absent in production versions.

(Photo CERN 544.4.89)

ing long gating times. Other noble liquids such as xenon and krypton are faster, and, provided bulk supplies can be tapped at reasonable prices, would be an attractive proposition. Liquid xenon chambers have been studied recently because of their promise for electron/pion discrimination using both light and ionization signals. Room-temperature liquids provide another line of attack.

Among crystalline materials, BGO, barium fluoride and pure cesium iodide are the most interesting, however their radiation resistance at LHC levels is not known. New materials may yet appear, while radiation resistance, light sensors and low noise analog circuits require further investigation.

'Straw' proportional chambers with multilayer polypropylene tubes around a single wire would be an effective electron identifier with good position resolution as well. Polyethylene foam between layers

could enhance the transition radiation effect.

A high proportion of the investment in a future collider experiment goes into front-end electronics, triggering and data acquisition systems. Here sophisticated solutions from industry can be adapted. RISC computers may give enough computing power (1000 VAX Mips), and improved magnetic storage media could increase the data storage capacity by another factor of 100. More of a worry are the front-end electronics requirements, data transfer from the detectors to the controls, and the development of standard acquisition systems. As recently-appointed ECFA Chairman J.E. Augustin of Orsay pointed out in his summary, electronics and data acquisition may well turn out to be the cornerstone of future systems, with development work warranting correspondingly high priority.

Industry took a very active part

Stanford survives 7.1 shock

in the Study Week, with some 30 companies represented. Speakers included delegates from the Norwegian Centre for Industrial Research and from Micron, UK, covering silicon research, ABB-HAFO covering manufacture of radiation-resistant analog chips, Hamamatsu, Japan, with new photonic detectors, BDH, UK, with crystal fabrication, Schott, West Germany, with scintillating glass and fibres, and Bofors, Sweden, with work for the Delphi experiment at CERN. M. Lea from Brunel University and ASPEX, UK, reviewed the rapid evolution of embedded parallel structures. S.-O. Flycht of Philips in the Netherlands, one of the most faithful participants from industry to meetings of this type, surveyed how fruitful contacts with industry had developed. Finland too was an interesting case history.

Representing the Commission of the European Communities, C. White explained the procedures for requesting support. This funding could go on to become a very important stimulus for ongoing industrial cooperation.

The rapid progress of the past two years boosts confidence for building LHC detectors to contend with the proposed high collision rates. When more effort becomes available after the construction and commissioning of the LEP detectors at CERN, this R&D work should not only continue but expand, capitalizing on the head start given by the Italian-funded LAA programme.

From Enrique Fernandez and Goran Jarlskog

Although relatively near the epicentre of the San Francisco earthquake, the Stanford Linear Accelerator Center (SLAC) suffered minimal damage.

The Monday morning of 16 October looked like the start of a quiet week at the Stanford Linear Accelerator Center (SLAC). After a successful six-month physics run, the SLC Stanford Linear Collider was shut down to begin scheduled upgrades and the installation of two vertex detectors for the Mark II detector. Then at 5.04 p.m. the next day, the Earth's crust had had enough. A major earthquake measuring 7.1 on the Richter scale rocked the San Francisco Bay Area from an epicentre along the wicked San Andreas Fault in the Southern Santa Cruz mountains.

Advancing northwards along the San Francisco peninsula at speeds up to three kilometres per second, the mighty shock waves radiated outwards, ripping through the bedrock of 25 million-year-old Miocene sandstone on which SLAC rests, shaking the Laboratory with accelerations of up to a third of that induced by gravity on the Earth's surface. The violent shudder lasted for twenty seconds.

People dashed for doors or dived under desks to avoid the hail

of ceiling tiles, books and other falling objects. Physicists standing on one of the teetering endcaps of the SLD detector (being prepared for its SLC career) clung to its railing, hoping the upright iron slab would not topple onto the concrete floor fifty feet below. A hapless technician suspended in a bucket from the overhead crane swung helplessly to and fro above the gaping pit as the thousand-ton crane slid back and forth in its tracks.

Minutes later, after the main jolt had passed but the Laboratory still quivered in the numerous aftershocks, staff began to look at the damage. Miraculously, nobody was hurt. Primary damage to buildings and equipment seemed relatively minor – a few wall cracks, some minor leaks, a vacuum chamber torn open at its seams, broken transformers, ground faults in magnets and power supplies.

The lack of serious damage testified to the foresight in building SLAC according to stringent standards which far exceeded those of local building codes, and to the vigilant watchdog work of the Earthquake Safety Committee. For years its members had gained in unpopularity by badgering all and sundry to bolt cabinets to walls and secure anything that could topple. Overnight they became heroes.

As people looked more carefully, more secondary damage was uncovered. Most worrisome for the immediate future of SLAC were the small misalignments in the linear accelerator waveguide and of the magnets in the SLC arcs. In his 'State of SLAC' talk the following Monday, Director Burton Richter said these problems would delay the SLC schedule by at least a week and perhaps up to three months.

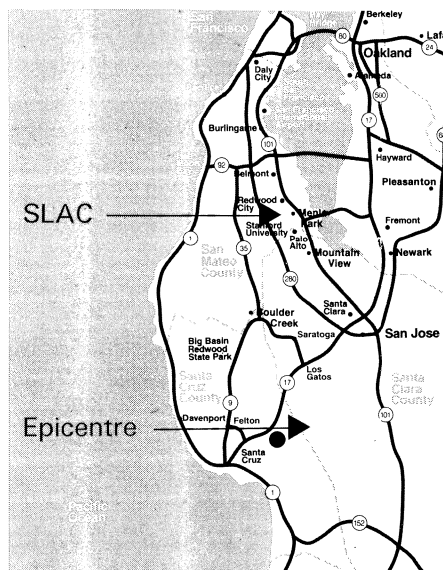

Using a laser aimed down the aluminium tube supporting the two-mile copper waveguide of the main linear accelerator, surveyors found a one-centimetre dip where the machine had been built on landfill rather than sandstone. However settling had happened before, and good solutions had been found. More problematical were small shifts of the thousand or so magnets used to bend and guide electrons and positrons through the SLC arcs. Getting these magnets properly positioned in the first

place had been no easy task, and realignment would not be much easier.

The two SLC detectors survived with only minor damage. Mark II developed a water leak in a heat shield, and bearings were damaged in the structure supporting its endcaps. Most impressive was how SLD survived, even though only partially assembled. Its endcaps swayed but did not topple; its 600-ton liquid-argon calorimeter rocked inside its enormous dewar, but four huge 'earthquake snub-

bers' at the ends worked as designed and damped out the vibrations.

While SLAC was lucky to have avoided the devastation that hit the rest of the Bay Area in the Great Quake of 1989 – the most destructive to hit the US since 1906 – it reaped the benefits of years of foresight and planning for just such an eventuality.

From Michael Riordan

Applying the accelerator

Originally developed as tools for frontier physics, particle accelerators provide valuable spinoff benefits in applied research and technology.

These accelerator applications are the subject of a biennial meeting in Denton, Texas, but the increasing activity in this field re-sulted this year (5-9 September) in the first European Conference on Accelerators in Applied Research and Technology, organized by K. Bethge of Frankfurt's Goethe University.

The meeting reflected a wide range of applications – ion beam analysis, exploitation of nuclear microbeams, accelerator mass spectrometry, applications of photonuclear reactions, ion beam processing, synchrotron radiation for semiconductor technology, specialized technology,.... Even so, an equally wide range of topics could not be covered, including radiation therapy

and ion beam surgery, radiation processing of food and polymers, waste sterilization and pollution reduction, mineral prospecting, explosive detection,....

Ion beam analysis

Ion beams are used to analyse elemental composition in many different research fields (materials science, metallurgy, geology, biology, medicine, archaeology, art,....). The main techniques used are – Rutherford Backscattering (RBS), Proton-Induced X-ray Emission (PIXE), Charged Particle Activation Analysis (CPAA) or Nuclear Reaction Analysis (NRA), Secondary Ionization Mass Spectrometry (SIMS), Particle Desorption Mass Spectrometry (PDMS), and Extended X-ray Absorption Fine Structure (EXAFS) using synchrotron radiation.

Many of these techniques are now well established and have their own tightly knit communities. NRA, well suited to light elements in heavy substrates (metals), is emerging in metallurgy and is being used particularly in studying the new generation of high-temperature superconductors, revealing what a sample really is, rather than what it was intended to be before its constituents were made to react.

CPAA is useful for ultra-low concentrations and in wear studies. Applicable to most elements, it is sensitive down to one part per billion (10^{-9}). A range of ion energies (1-45 MeV) probes depths ranging from microns to millimetres. In wear studies, a thin surface layer is activated, and the consequent drop in activity reflects the underlying wear process. An example is the effect of acid-alkali level on corrosion in nuclear reactor materials.

De l'original à l'imprimé...

Tout est question de fidélité.

*Les techniques changent. Les hommes aussi. Seul demeure
l'amour du métier et du travail bien fait.*

*Aujourd'hui, les exigences en matière d'impression
n'ont jamais été aussi élevées.*

Les PCL sont là pour vous le prouver.

*Derrière les machines vous attendent des hommes qui ont
déjà choisi d'imprimer avec les moyens de demain.*

PCL

*Presses Centrales Lausanne SA
7, rue de Genève 1002 Lausanne
Tél. 021/20 59 01 Téléfax 021/20 59 50*

La qualité qui communique

Ion implantation is now widely used to improve the surface properties of tool and machine components.

(Photo Leybold AG)

Nuclear microbeams

Scanning by spot-size ion beams has transformed the PIXE technique from an analytical tool into an imaging device to map the distribution of elements – a veritable nuclear 'microscope'.

The resulting element maps, reminiscent of the structure revealed by optical or electron microscopy, are of particular appeal to biologists or medical specialists more used to images than to spectral profiles.

The technique uses a 2 to 4 MeV accelerator (usually a tandem Van de Graaff), a probe (focussing quadrupoles, scanning coils and collimators), a detector and a data acquisition/processing package.

Recent advances have reduced the spot size to a few microns, however resolution (depending on the spot size) has to be reconciled with sensitivity, requiring bright sources (but not so bright as to destroy the sample!).

This technique is finding increasing use. Geoscience applications include element zoning in minerals, inclusion composition, and grain boundary analysis. Its power in life sciences has been vividly demonstrated by studies on Alzheimer's disease which show that the characteristic senile plaques in the brain contain large proportions of inorganic elements such as aluminium, silicon, titanium or iron. Meteorites, pigment layers in old paintings, multilayer semiconductors, welds, corrosion, high temperature superconductors,.... are just a few examples of structure studies with PIXE. Combined with the depth profile given by RBS (Rutherford Back-Scattering), a full three-dimensional element distribution can be mapped.

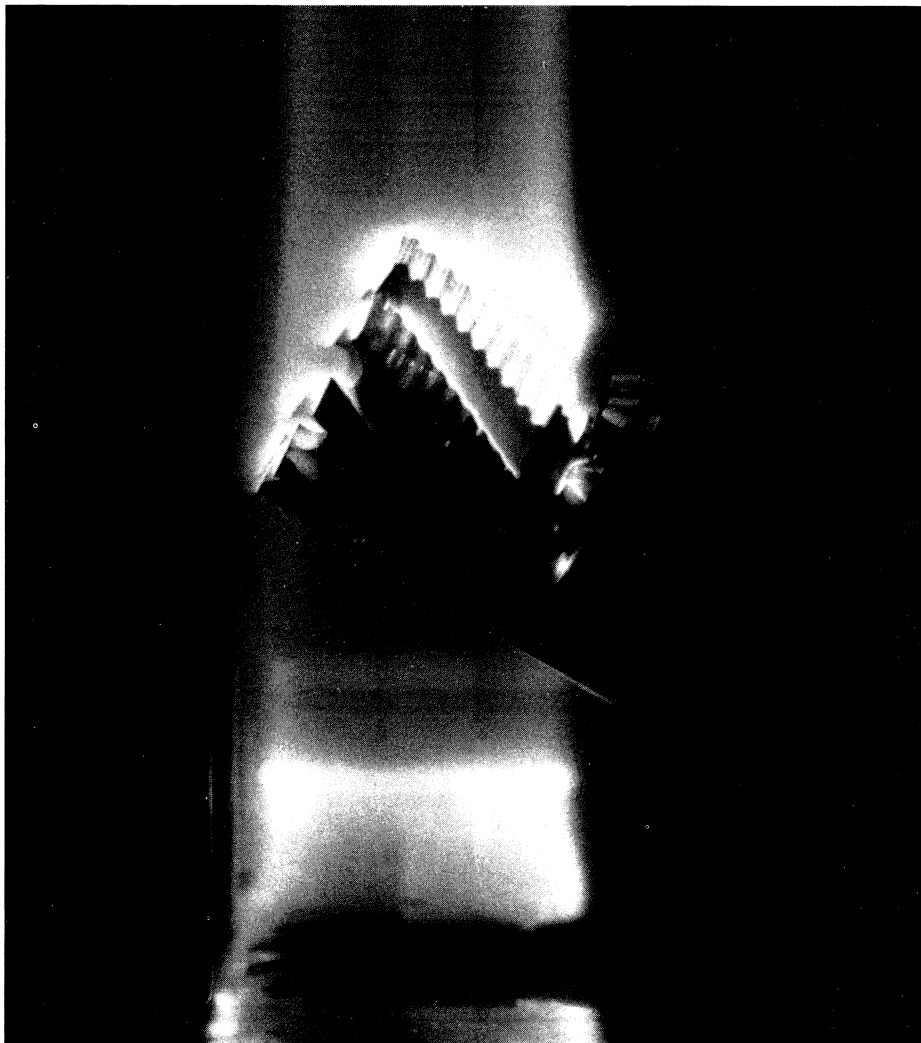

Accelerator mass spectrometry (AMS)

While in ion beam analysis the accelerator's beam bombards the sample and a detector picks up the results of the induced atomic or nuclear processes, in accelerator mass spectrometry a sample is ionized, accelerated and analysed directly, the sensitivity being limited by the measuring time.

Applications are again abundant – archaeology, art, paleoanthropology, geology, paleoclimatology, extraterrestrial mineralogy, biology,....

AMS is used in the majority of radiocarbon dating measurements, giving a much greater sensitivity than the more traditional method of counting the beta decays of carbon-14. The recent corroboration by three Laboratories (Arizona, Oxford and Zurich) of the age of the Turin shroud based on milligram samples is a case in point.

AMS is also a useful monitoring

procedure in the semiconductor industry, where device performance can be easily degraded by source impurities. AMS can give a hundredfold better sensitivity than conventional SIMS (Secondary Ion Mass Spectrometry) analysis.

Application of photonuclear reactions

Sufficiently energetic photons (above 5 MeV) give a variety of useful nuclear reactions. The result of bremsstrahlung from electrons passing through a heavy metal, these photons are produced more efficiently at higher electron energies, the conversion rate increasing tenfold from 5 MeV to 70 MeV.

In Photonuclear Transmutation Doping (PTD) of semiconductors, silicon-30 can be produced in phosphorus-31, the subsequent beta-emission giving an n-type doped material, while silicon-28 can produce aluminium-27, a p-type dopant.

Electron micrograph of an IBM computer chip made using X-ray beams from the US National Synchrotron Light Source at Brookhaven. The metal lines are less than a micron across.

Other potential PTD applications include fission product 'incineration', where long-lived dangerous fission products such as strontium-90 (mean life 28 years) could be converted into shorter-lived isotopes (in this case strontium-89, with a lifetime of only 50 days). However this would need extremely high photon fluxes, of the order of 10^{18} per sq cm per s, and doubts were expressed on the economics of such a proposal.

Ion beam processing

Ion beam implantation is now well established in the semiconductor industry. Complementing the 3000 or so centres worldwide concentrating on surface treatment comes now ion beam synthesis, to bury insulators (such as silicon oxide or nitride), conductors (metal silicides or metals) or semiconductors (silicon carbide) inside a silicon substrate.

The choice of energy dictates the implantation depth (100 to 350 keV for the submicron range, several MeV to penetrate to micron depths). High doses (10^{17} to 3×10^{18} ions per sq cm) are needed to create the buried layer. Any resultant defects are removed by annealing at high temperature.

Ion implantation can startlingly change surface properties, tools and components becoming up to a hundred times more wear resistant. With nitrogen ions, this effect is now understood as the formation of coherent precipitates of very finely divided nitrides which pin dislocations and increase resistance to shear stress.

The process can be carried out at low temperature and does not distort components, gives no boundaries liable to move under

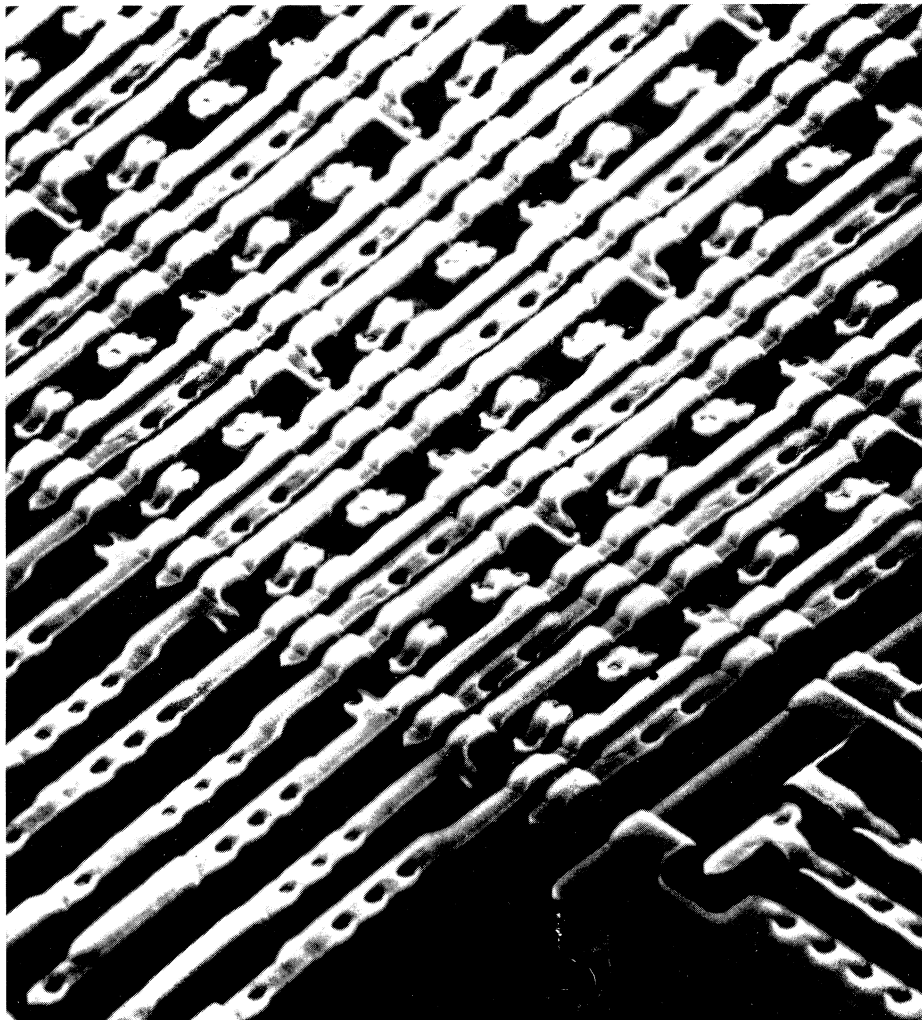

stress and/or corrosion, leaves a good surface finish and can be accurately controlled at all stages.

Besides tools, it is also used for engine bearings and turbines in the automotive and aeronautical industries. A related application is ion beam mixing to give increased diffusion of coatings and better adhesion.

Increasing beam intensity from 4 to 40 mA allows larger surfaces to be treated and reduces processing time. A new example is ion processed hip, knee and shoulder joints. However cost limits application to cases where an essential demand for a high quality product makes such meticulous care justifiable.

Synchrotron radiation in semiconductor technology

The most successful application of all, synchrotron radiation, widely used for structure analysis in many different fields of science, now looks set to assume an additional

important role in microlithography for large capacity computer memories.

Smaller spacings (line widths) on mass-produced computer chips could open the door to memory chips holding more than 64 Megabits (October 1988, page 28). For this, pattern definition must reach 0.15 micron, requiring highly parallel radiation sources as at these wavelengths optical lenses are ruled out.

Another example of synchrotron radiation at work is in the micromechanical manufacture of nozzles for uranium isotope separation.

Accelerator technology

The first wave of accelerator applications made parasitic use of machines built for fundamental research. Subsequently, dedicated but nevertheless general-purpose machines appeared, such as those used for synchrotron radiation sources.

Physics for KAON

Now emerging is a new generation of special purpose machines custom-built for a particular field. An example is the Berlin Compact Synchrotron (COSY) optimized for work with high density semiconductor devices. Similar projects are afoot in the US and Japan.

In the field of ion implantation, originally dominated by classical electrostatic machines, there is a call for higher energies and intensities to probe deeper sample layers. With electrostatic machines in the MeV range being cumbersome and of limited intensity, radiofrequency quadrupoles (RFQs), now being increasingly used as ion injectors in physics Laboratories, could fit the bill. While they are compact and easy to operate, they are more difficult to tune and the initial design requires careful attention.

With high energy physics becoming increasingly dominated by large Laboratories using giant accelerators, the accelerator applications field is moving the other way, towards small, specially-designed machines.

From Oscar Barbalat



Canadian TRIUMF Laboratory Director Erich Vogt – looking for international partners for the KAON project. ►

The KAON high intensity beam factory project at the Canadian TRIUMF Laboratory in Vancouver (October, page 9), continues to receive favourable ratings by US nuclear science advisory groups. Only the CEBAF Continuous Electron Beam Accelerator Facility under construction at Newport News, Virginia, and the RHIC heavy ion collider proposal at Brookhaven are accorded higher priority.

Meanwhile to estimate, stimulate and coordinate physics interest the KAON project team has organized a series of international physics workshops, including one at Bad Honnef in Germany earlier this year.

As well as advertizing the advantages of signing up for KAON, these meetings also reflect some of the problem areas of current physics rarely mentioned in the mass meetings which worship the Standard Model.

Aimed to give future European users an opportunity to shape KAON plans, the Bad Honnef meeting also covered the complementary physics offered at the French Saturne Laboratory at Saclay and the COSY cooler/synchrotron project underway at Jülich in Germany.

Half the talks covered possible strong interaction experimental programmes at KAON, with hadron spectroscopy, where both the theoretical and experimental situations are very unclear, dominating the discussions. The experimental state of affairs was covered in four talks. David Bugg proposed a device to provide full angular coverage of strange baryon resonance production, with better statistics than available bubble chamber data.

Suh-Urk Chung discussed past and future experiments in the mass region of the $\iota/\eta(1450)$. Bill Dunwoodie described the LASS

spectrometer experiment, emphasizing that new spectrometers built for this type of work at KAON must, to avoid kinematical gaps that could result in 'false' states, strive for wide angular coverage.

The theory of hadronic systems was discussed by Frank Close, Stephen Godfrey, Piet Mulders, Fred Myhrer and Josef Speth. The predictions of simple quark-based models are quite successful, however some predicted states are not seen at all while others are seen in the wrong place. Godfrey concluded that a lot more experimental information is needed to decide if a state seen experimentally is a predicted exotic (glueball or hybrid).

KAON would contribute significantly to the physics of hypernuclei (including 'nucleons' carrying strangeness). Bob Chrien discussed kaon production in this context, demonstrating its power for testing models of hypernuclei with recent data from Brookhaven. Peter Barnes proposed an apparatus for the study of light hypernuclei and Stephan Paul described the present muddled status of hypernuclei containing sigma particles, and presented an apparatus to study the problem at KAON.

The long mean free path of positive kaons in nuclear matter has led to expectations of important information on nuclear properties from studies using these particles. Otto Häusser compared this type of experiment to the present nucleon-nucleus program at TRIUMF.

Accelerating polarized (spin oriented) protons to intermediate and high energies is tricky, demanding negotiation of many depolarizing resonances. Alan Krisch indicated a new solution, describing the success of recent preliminary tests of 'Siberian Snakes' at the Indiana Cyclotron (June, page 23),

and highlighted the continuing interest of spin-dependent measurements, where in some cases the relevant production rates are extremely small. Andy Miller described an internal target facility for KAON that could achieve luminosities of 10^{33} , stressing that such a feature should be supported now if it is not to be 'designed out'.

KAON's intense antiproton beams could be used to create high energy densities inside nuclei, as explained by Bill Gibbs. Exotic atoms and exotic hadron states produced by antiprotons were discussed by Leo Simons and Eberhard Klempt respectively.

Our present understanding of the non-strangeness-changing weak interactions of hadrons is based on high precision experiments which isolate the weak interaction via its characteristic left/right asymmetry

signature. Shelley Page described the need for measurements at energies above 5 GeV, concluding that such experiments could be performed with KAON polarized beams.

Definitive detection of any forbidden decays, in particular of kaons, would challenge the Standard Model and indicate new directions. Extensive work on rare kaon decays is underway at several major Laboratories. Doug Bryman showed how higher intensity beams will allow for much greater precision and sensitivity in such experiments.

The proposed KAON Driver ring (October, page 10) could be a very good source of neutrinos, and the physics potential was outlined by Florian Scheck.

In summarizing the meeting, TRIUMF Director Erich Vogt also

described how the Canadian Laboratory is pursuing its KAON goal, encouraging international partners to contribute to the construction. The strong interest in KAON within the German community was very apparent at Bad Honnef.

Other meetings in the KAON series have been held at TRIUMF itself and at Montreal in Canada, at the Japanese KEK Laboratory, at Coimbra in Portugal, and most recently in Turin, where a special topic was the possibilities for antiproton facilities. A further meeting planned for Vancouver next summer will aim to catalyse the formation of collaborations to develop experimental proposals and to canvass the requirements for beamline and detector design. Further information from Pat Stewart at TRIUMF (STEWART at TRIUMFCL).

Around the Laboratories

CERN First physics from LEP

On 13 October, four days after the end of the first physics run of CERN's new LEP electron-positron collider, all auditorium space and every closed-circuit TV vantage point was taken for presentations by the four experiments – Aleph, Delphi, L3 and Opal.

With good performance from the machine, the experiments had amassed between them over ten thousand Z particles – the electrically neutral carriers of the weak

nuclear force – and physicists were eager to learn the first fruits of the world's largest catch of Zs.

Discovered in the 1983 tour de force at CERN's proton-antiproton collider which resulted in the Nobel prize for Carlo Rubbia and Simon van der Meer, the Z had, until earlier this year, been reserved for the big experiments at the proton-antiproton colliders, first at CERN and then at Fermilab.

With the advent of physics this year at Stanford's SLC linear electron-positron collider, the Mark II detector also joined the action, supplying the first few hundred examples of Zs produced in electron-

positron annihilations. After a sweep across the Z region, Mark II's physicists improved on previous measurements of the mass of the particle. From the Z production rate around the peak, they also got an improved limit on the different number of lightweight neutrino types allowed in Nature (November, page 1). These results showed that there was very little room left for a fourth neutrino type to complement the three (electron-, muon- and tau-types) known so far.

With the deluge of statistics from LEP, the four experiments could significantly refine the accuracy of the Z mass measurement.

Experiment	Mz (GeV)	Total Width (GeV)	Number of neutrinos
ALEPH	91.174	2.68	3.27 ± .30
DELPHI	91.06	2.42	2.40 ± .40 ± .50
L 3	91.132	2.588	3.42 ± .48
OPAL	91.01	2.60	3.12 ± .42

The LEP team was able to calibrate the absolute energy of the machine to 45 MeV, only a few parts in ten thousand at the Z mass of 91.1 GeV. This is now the largest uncertainty in the Z mass.

With the electroweak picture qualitatively in excellent shape after the accumulated results of recent years, this precision measurement opens the door to a new era of quantitative electroweak studies, analogous to the landmark measurements of the Lamb shift and the anomalous magnetic moment of the electron which transformed quantum electrodynamics from an attractive idea into a cornerstone of modern physics.

But the most significant of the initial wave of LEP results is the removal of the remaining uncertainty in the count of neutrino species, with the chances of a fourth light neutrino now down to less than one in a thousand.

Concentrating for the moment on the decays of Z into strongly interacting particles (hadrons), the experiments' spectra correspond very closely with models of quark 'hadronization', boosting confidence in our understanding of fundamental interactions.

With a total of well over ten thousand Zs between them, the four experiments at CERN's LEP electron-positron collider give a precision fix on the mass and width of the Z and the allowed number of light neutrinos (with respective errors: the figures leave out a 45 MeV uncertainty in the LEP energy calibration.) Taken together, the neutrino limits imply that the chances of a fourth such particle are now less than one in a thousand.

Over the coming months, LEP experiments should go on to accumulate hundreds of thousands of Zs, with millions being the ultimate target. The search is on for the elusive Higgs particle (July/August, page 1).

Trapped nuclides

As well as exploring the high energy physics frontier, physicists at CERN get valuable complementary information from low energies. Earlier this year a team using a Penning trap at the LEAR low energy antiproton ring attained new record low energies for antiprotons (September, page 23).

(The important role of ion traps in modern physics was underlined in the award of this year's Nobel Physics Prize – see page 23.)

Recently another trapping group, this time a Mainz-McGill collaboration working at the ISOLDE isotope separator, directly measured the masses of a wide range of cesium radionuclides with precisions of one tenth of a part per million, far exceeding anything previously attained for short-lived nuclei.

The mass of a nucleus is one of its most basic properties, yet it is known accurately for only stable and long-lived species. The masses of short-lived nuclei, such as exist in the interior of hot and exploding stars, are usually only 'known' by extrapolating nuclear models.

Schematic of the CERN ISOLDE radionuclide mass measuring system. The Paul trap should be installed early next year.

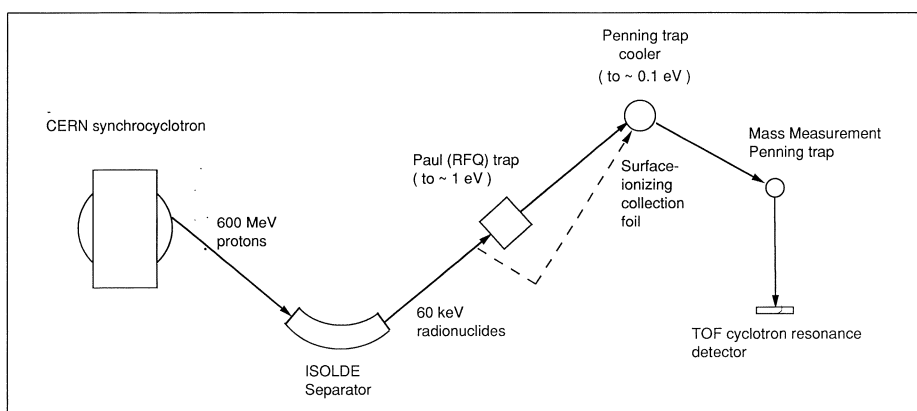

In its definitive state, the Mainz-McGill experiment's 60 keV radionuclide ions from ISOLDE will be first arrested in a radiofrequency (Paul) trap and cooled to about 1 eV before entering the remainder of the apparatus. With this trap still under development, the experiment used instead a surface-ionizing collection foil in the downstream Penning trap. Here the ions are cooled to about 0.1 eV before being delivered to a measuring trap, where they are gently tickled by a cyclotron radiofrequency field to about 20 eV for about a second before finally being ejected to a time-of-flight (TOF) detector.

The radionuclide mass is given by the frequency of the cyclotron field at resonance, detected by its effect on the TOF when the cyclotron energy is transferred to axial motion during the final ejection. Despite the absence of the Paul trap, the experiment achieved unparalleled precision measurements on nuclei ranging out to 14-second cesium-118.

This winter will see installation of the Paul trap collector to complete the system. CERN will then be in a unique position to test some of the most fascinating features of nuclear structure such as the mass of 10-millisecond lithium-11 which, on the basis of laser spectroscopy also carried out at ISOLDE, appears to be a diffuse two-neutron halo surrounding a lithium-9 core. If so, this halo is probably as near as we are ever going to get on earth to the interior of a neutron star.

At the recent charged particle acceleration workshop organized by the Yerevan Physics Institute, Armenia, left to right, Robert Palmer (Brookhaven/Stanford), A. I. Artyemyev (Inst. of General Physics, Moscow) and Alexander Varfolomeev (Inst. of Atomic Energy, Moscow).

YEREVAN Acceleration workshop

Sponsored by the Yerevan Physics Institute in Armenia, a Workshop on New Methods of Charged Particle Acceleration in October near the Nor Amberd Cosmic Ray Station attracted participants from most major accelerator centres in the USSR and further afield.

The programme covered the wide range of new acceleration techniques currently under investigation – plasma acceleration, inverse free electron lasers, inverse Vavilov-Cherenkov effect, laser applications, two-beam and wake field techniques.

A similar workshop had been held in 1982, and the progress made since then was very evident. The next meeting is scheduled for 1992.

FERMILAB Physics in the 1990s

Brainstorming workshops are a regular feature of the high energy physics scene, but a recent Workshop on Physics at Fermilab in the 1990s was one of the most important in the Laboratory's 20-year history, charting the aims of a research centre which will retain the distinction of having the highest energy accelerator in the world well into the next decade.

From 1985, the future of Fermilab had been intimately tied to the possibility of siting the proposed SSC Superconducting Supercollider in Illinois. With the decision to build the SSC in Texas, Fermilab has to fashion a new identity in support of but ultimately separate from the SSC.

The fervour at the Workshop, held in the Rocky Mountains at

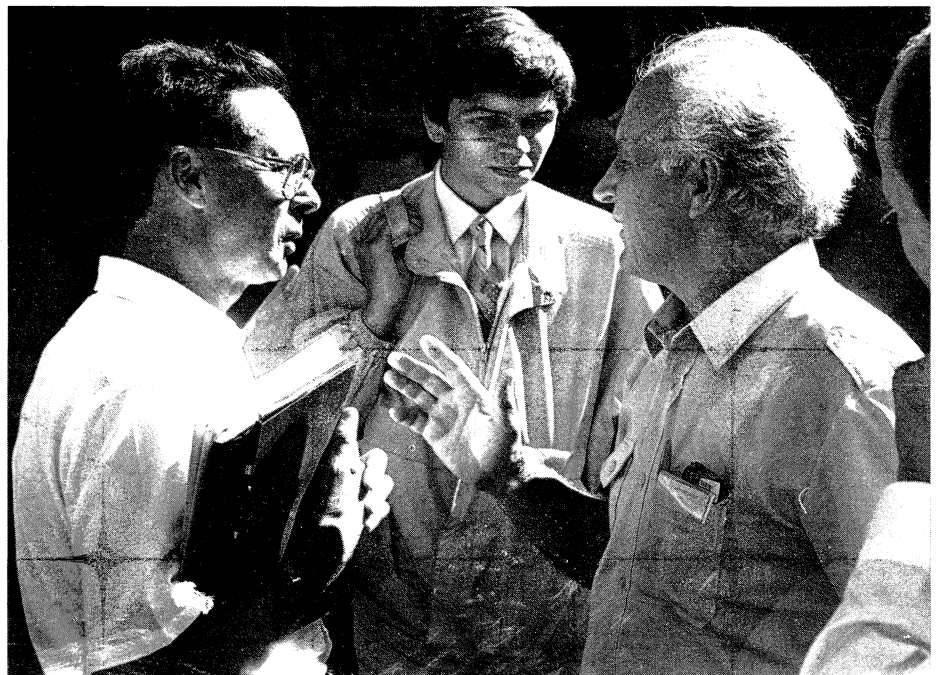

Breckenridge, Colorado, was eloquently expressed in a quote from Einstein which adorned the wall of the Workshop computing room – 'Great spirits have always encountered violent opposition from the mediocre minds.' With many participants working long into the night, there was often a waiting line for the 40 terminals of a local VAX cluster totaling 27 Mips of computing power which was linked to Fermilab's central computing facility.

With the goal of exploring the territory between the current W and Z and the future SSC energy regions in both collider and fixed-target modes, Fermilab has begun to define its new identity by proposing a three-phase upgrade of which the first (the Linac Upgrade) is already underway (September 1988, page 16).

In mid-May, interested physicists came together at Fermilab to study the second phase of the upgrade, the Main Injector. This 120 GeV, large-aperture, rapid-cycling proton synchrotron, designed specifically to overcome limitations inherent in the existing Main Ring when used for collider operations, would be built in a new tunnel.

Together, the Linac Upgrade and the Main Injector would double the currently available flux to 3×10^{13} protons per pulse, and most important, boost collision rates, with luminosity increasing to 5×10^{31} .

The Main Injector would also supply 120 GeV protons for fixed-target work, in parallel with collider operations, so that the Laboratory would have particle beams available year round.

The Main Injector Workshop focussed on the fixed-target physics possible with this higher intensity beam, including high sensitivity kaon decays, high-flux neutrino- and antiproton-initiated processes,

together with detector and beam-line design requirements.

Possible future fixed-target and collider options with the Main Injector were further clarified at the Breckenridge Workshop.

Breckenridge also saw lively discussion on a revitalized 'Dedicated Collider' proposal using 6.6-8.6 tesla superconducting magnets, yielding a collision energy of 6-8 TeV, depending on the magnetic field. This 'LINCOLN' (Large Independent Collider Nearby) machine would be a step beyond the Main Injector.

Working group summaries provided a framework for the upgraded accelerator and physics options at Fermilab during the next decade and beyond. A major aim was to identify the most pressing theoretical issues, the tell-tale signatures of new effects, and ways of extracting these rare events from a background of conventional physics.

In his workshop summary, Jonathan Rosner (Chicago) produced an exciting menu of physics topics, including W and Z radiative corrections, new electroweak tests, precise measurements of quark-lepton mixing parameters and further probes of CP violation.

Summary sessions began with Mitchell Golden (Fermilab) and Keith Ellis (Fermilab) laying out the theoretical geography of physics with the Main Injector and beyond. With these issues on the table, discussions moved to questions on the myriad physics options possible with a higher intensity and luminosity upgrade.

What physics can be done only with the Main Injector? How can experiments accumulate large data samples? What are the significant background problems and how can these be addressed? Do other ap-

proaches give better measurements and a more cost-effective detector design? Can detectors be polyvalent? Can more than one experiment use the same detector? The resulting debate will probably produce both letters of intent and full-blown proposals that will be submitted to the Fermilab Physics Advisory Committee (PAC).

The role of fixed-target experiments at Fermilab in the light of the demand for SSC test beams and in an increasingly collider-oriented environment came in for special attention. Many participants felt that fewer and more carefully chosen fixed-target experiments should be approved, to benefit from the full resources of the fixed-target programme. This would hasten the progress of an experiment from proposal to completion.

For future charm and B-meson physics in both the fixed-target and collider modes, Joel Butler (Fermilab) claimed that fixed-target experiments dominate current measurements of charmed particle lifetimes and are quite competitive with electron-positron colliders for both rare decay modes and heavier charm states. He concluded that charm physics is still a viable route and that Fermilab is competitive.

In the fixed-target B physics sector, the first high sensitivity experiments will begin taking data in the upcoming run. A key to future fixed-target B physics at Fermilab is the low signal-to-background ratio compared to electron-positron and even high energy hadron colliders. With the available fixed-target 'luminosity' so high (10^{34}), the potentially large yields are tantalizing even though they are difficult to pull out of the high backgrounds.

The consensus was that continued and increased work on detec-

► page 24

EXPERIMENTAL ELEMENTARY PARTICLE/ COSMIC RAYS PHYSICS

The Physics Department at the University of Utah is seeking two qualified candidates for tenure-track positions in experimental particle/cosmic ray physics at the assistant professor level or higher.

The successful candidates will be expected to participate in the work of the Fly's Eye Ultra High Energy Cosmic Ray observatory and allied efforts.

Candidates should submit their curriculum vitae, list of publications and three letters of recommendation by March 15, 1990 to:

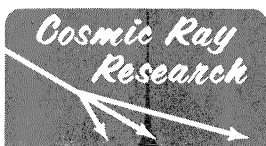

UNIVERSITY OF UTAH

Faculty Search Committee,
Department of Physics
201 James Fletcher Building
University of Utah
Salt Lake City, UT 84112

*The University of Utah is an Equal Opportunity,
Affirmative Action Employer.*

THE UNIVERSITY OF ARIZONA FACULTY POSITIONS IN PHYSICS EXPERIMENTAL RELATIVISTIC HEAVY ION COLLISIONS CONDENSED MATTER THEORY THEORETICAL ASTROPHYSICS

The Department of Physics at the University of Arizona is in the midst of a major faculty expansion program, extending through the next few years. We plan to make faculty appointments in one or more of the above fields starting in the 1990-91 academic year. In addition, candidates for new positions in other subfields of physics may be considered.

We expect to make the majority of appointments at the tenure-track Assistant Professor level, but higher level positions are possible for exceptionally well-qualified individuals.

The Department of Physics enjoys close relations with the Departments of Astronomy, Mathematics, Optical Sciences, and Planetary Sciences, and will weigh these ties when making new appointments.

Faculty members are expected to maintain an active research program and to participate in the teaching and service activities of the Department.

Applicants should respond to

**Prof. Peter Carruthers,
Head, Department of Physics,
University of Arizona,
Tucson, AZ 85721.**

The review of applications will begin **January 1, 1990** and will continue until the positions are filled.

Applicants who wish to be considered should submit their curriculum vitae and a statement of research interests, and arrange to have three letters of recommendation sent directly to Prof. Carruthers.

The University of Arizona is an EEO/AA Employer. We especially encourage applications from women and minorities.

BROOKHAVEN NATIONAL LABORATORY

National Synchrotron Light Source Department Scientific Staff Vacancies

Physicist (Position #001)

Applications are invited from individuals with a strong record of accomplishment in the field of Accelerator Physics to serve as head of the Accelerator Physics Section at the National Synchrotron Light Source Department. Activities will be directed to the operation and enhancement of the existing storage rings. Important areas of work are the study of beam intensity limiting effects, orbit stabilization, and development of the related hardware. The selected candidate will also be involved in the development of Free Electron Lasers and the development and construction of a compact synchrotron source.

Physicist (Position #002)

Applications are invited from individuals with a broad background in experimental particle accelerator physics. Activities will be directed to the operation and enhancement of the existing storage rings. Important areas of work are the study of beam intensity limiting effects, orbit stabilization, and development of the related hardware. The selected candidate will also be involved in the design, construction, and commissioning of a compact, superconducting storage ring dedicated to X-ray microlithography.

Those responding should indicate the position desired and submit a curriculum vitae that includes the names of three references to: Dr. S. Krinsky, Acting Chairman, National Synchrotron Light Source Department, Building 725B, Brookhaven National Laboratory, Associated Universities, Inc., Upton, L.I., NY 11973. Equal Opportunity Employer m/f.

BNI BROOKHAVEN
NATIONAL LABORATORY
ASSOCIATED UNIVERSITIES, INC.

FACULTY POSITION EXPERIMENTAL HIGH ENERGY PHYSICS NORTHWESTERN UNIVERSITY

The Northwestern University Physics and Astronomy Department invites applications for a tenure track position in Experimental High Energy Physics. The Department now has 7 faculty members active in this area and the group is supported by DOE.

At present, the research effort encompasses the following experiments: $p\bar{p}$ interactions (Fermilab E740), photo-production of charm states (E687), resonant production of charm states (E760), heavy quark production (E771), $p\bar{p}$ elastic cross sections (E710), $p\bar{p}$ spin physics (E704), and investigations with a dilepton spectrometer (LBL 608).

The successful candidate will be expected to perform original and significant research, supervise graduate students, and be a competent teacher at all levels. Interested persons should send a curriculum vitae along with the names of three references to:

**Ralph Segel, Chair
Experimental High Energy Search Committee
Department of Physics and Astronomy
Northwestern University
Evanston, IL 60208**

Northwestern University is an Affirmative Action/Equal Opportunity Employer.

1989 Nobels

The 1989 Nobel Physics award to Norman F. Ramsey of Harvard, for the invention of the separated oscillatory fields method and its use in the hydrogen maser and other atomic clocks, and to Hans G. Dehmelt of Seattle, Washington, and Wolfgang Paul of Bonn, for their development of ion trapping, highlights precision measurement techniques which have gone on to play important roles, particularly in the definition of standards.

Not explicitly mentioned in the Nobel citation, but no less important, is the contribution of the Laureates in science policy and in promoting new projects.

Norman Ramsey was one of the founders of Associated Universities Inc, the governing body of the Brookhaven Laboratory, and from 1946-7 was first Chair-

man of Brookhaven's Physics Department. Later he was first President of Universities Research Association, the multi-university consortium set up in 1965 to manage what was to become Fermilab. This followed his work as chairman of a top-level committee set up in 1962 to assess the future US needs for high energy physics, setting the scene for much of what was to follow. With pioneer Fermilab Director Robert Wilson, Ramsey oversaw the creation of the major new national Laboratory.

In 1954, Wolfgang Paul launched the construction of a 500 MeV electron synchrotron at Bonn, the first machine in Europe to use the strong focussing technique. This was followed ten years later by the larger 2.5 GeV machine. With Directorship stints at DESY and Jülich in Germany, and a three-year period at CERN,

where from 1964-7 he was first joint Head of Nuclear Physics Division, then Director of Physics I Department, he has always returned to Bonn, where his inventiveness has been a continual source of inspiration. He was Chairman of CERN's Scientific Policy Committee in the formative years from 1975-77 when the 400 GeV SPS proton synchrotron came into action and the seeds were being sown for CERN's big projects for the coming decade.

Dehmelt's school in Seattle has been a prolific source of ideas and expertise on ion traps, increasing sensitivity to a level where Dehmelt, with P. Toschek in Heidelberg, succeeded in observing single ions. This technique has been further refined and applied, particularly at the US National Institute of Standards and Technology in Boulder, Colorado.

Two of the three physicists who went on to become this year's Nobel Laureates – Wolfgang Paul (at the microphone, left) and Norman Ramsey (seated, right) – were among the guests of honour at the inauguration of CERN's SPS proton synchrotron in July 1977. With them, left to right, were John Adams, Chris Llewellyn-Smith and Edoardo Amaldi.

(Photo CERN 223.5.77)



People and things

◀ continued from page 21

tor technology, triggering strategies and data acquisition and analysis capabilities is necessary. Interaction rates of some 100 MHz are expected, with a goal of examining a million tagged beauty events in an open geometry, yielding 10,000 fully reconstructed B mesons.

Carl Haber (Berkeley) looked at two approaches to B physics in collider mode. The first uses the existing CDF and D0 detectors to study the tail of the B spectrum. The second is a proposed Beauty Collider Detector (BCD), a large acceptance spectrometer designed for a broad study of B physics, especially CP violation.

The working group summary on symmetry violations and rare decays was given by Bruce Winstein (Chicago), pointing out relevant detector issues and the need for more development work. Collaboration during the Workshop between the CP violation working group and the detector group fostered solutions to envisaged problems in this sector.

Closing the Workshop, new Fermilab Director John Peoples underlined both the wide variety of physics possibilities and Fermilab's aim for a finely focussed, intensive assault on the most promising topics. For this to come about, he reaffirmed the need for the next logical step in this process, the new Main Injector.

The Workshop proceedings are published by World Scientific.

SERPUKHOV Channeling

The delicate steering and deflection ('channeling') of particle beams inside crystals is being increasingly studied at high energies. As well as

being an interesting physics topic in itself, it opens new applications potential for experimental physics.

At the Soviet Institute for High Energy Physics, Serpukhov, physicists have been looking at the possibilities of using crystals to extract beam from their 70 GeV proton synchrotron.

A recent success which promises much for the future was multi-turn extraction of protons by a deflector consisting of a bent single crystal of silicon. The channeled particles were shifted through 80 milliradians with an extraction efficiency of 5×10^{-5} .

Assembled as a sandwich, the single crystals allow the proton beam to be deflected through 60 mrad, with a resultant intensity in the range $10^5 - 2.5 \times 10^7$ protons per pulse.

(At Fermilab in 1984, a bent silicon crystal was used to replace a magnet in a secondary charged particle beam, raising the maximum momentum which could be transmitted from the magnetic septum limit of 225 GeV to the full primary beam level of 400 GeV.)

Detector specialist Georges Charpak (third from left), with some of the speakers at the seminar at CERN on 30 October marking his formal retirement – left to right, J. Saudinos, R. Garwin and Leon Lederman.

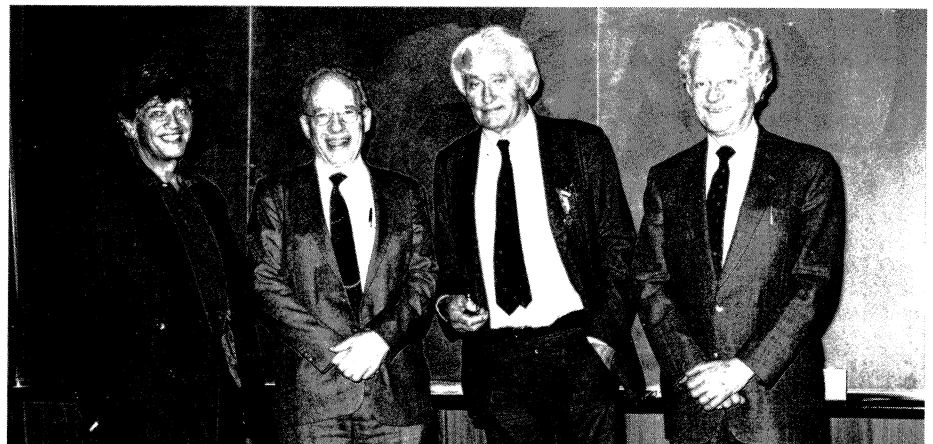

Georges Charpak at 65

Friends, colleagues and admirers of Georges Charpak filled the CERN Auditorium on 30 October for a special seminar marking the formal retirement of an acknowledged master of the particle detector business.

Before joining CERN in 1959, he had pioneered new methods for photographing the sparks left in the wake of particles. At CERN, he participated in the early measurements of the anomalous magnetic moment of the muon, and in experiments with pion beams.

Reverting to detectors, he investigated ways of localizing spark signals without resorting to photography. The result was the development of the multi-wire proportional chamber and the drift chamber, the workhorses of the modern particle physicist's detector stable.

Building on these ideas, and guided by his ambition and genius, his collaborators have gone on to develop important applications in imaging, precision microscopy, etc, while continually investigating the potential of new and sometimes exotic materials. This effort continues to bear fresh fruit.

Chaired by Pierre Lehmann and

The gas jet for the JETSET experiment at CERN's LEAR low energy antiproton ring (May 1987, page 21). The full experiment will be commissioned next summer.

(Photo CERN 172.10.89)

introduced by CERN Director General Carlo Rubbia and by a videoed Viktor Weisskopf, the seminar included contributions from Leon Lederman ('Superstrings need sealing wax'), underlining the pivotal role Charpak inventions now play in modern physics; from J. Saudinos, looking at Charpak's ambitions and successes in applying physics detectors to medicine and biology; from E. Uggerhoj on Charpak's push to extend channeling studies to high energy beams; and from R. Garwin, examining the wider role that concerned physicists, like Charpak, can and have played in society.

Presenting his mentor with a memento photo album, Fabio Sauli affirmed that the collaboration would be proud to continue to be called 'The Charpak Group'. In conclusion, Georges Charpak described some personal attitudes to initiating and motivating research. 'I have some detectors even more beautiful than the ones we have been talking about, but they are useless!' he declared, before avowing to continue his search for new ideas and techniques.

On people

Helen Edwards, now Head of the Accelerator Division at the US Superconducting Supercollider, SSC, and Dick Lundy, Rich Orr and Alvin Tollestrup of Fermilab have been awarded the US National Medal for Technology in recognition of their contributions in mastering superconducting magnets in the construction of the Fermilab Tevatron.

Former CERN Director General Herwig Schopper was awarded an

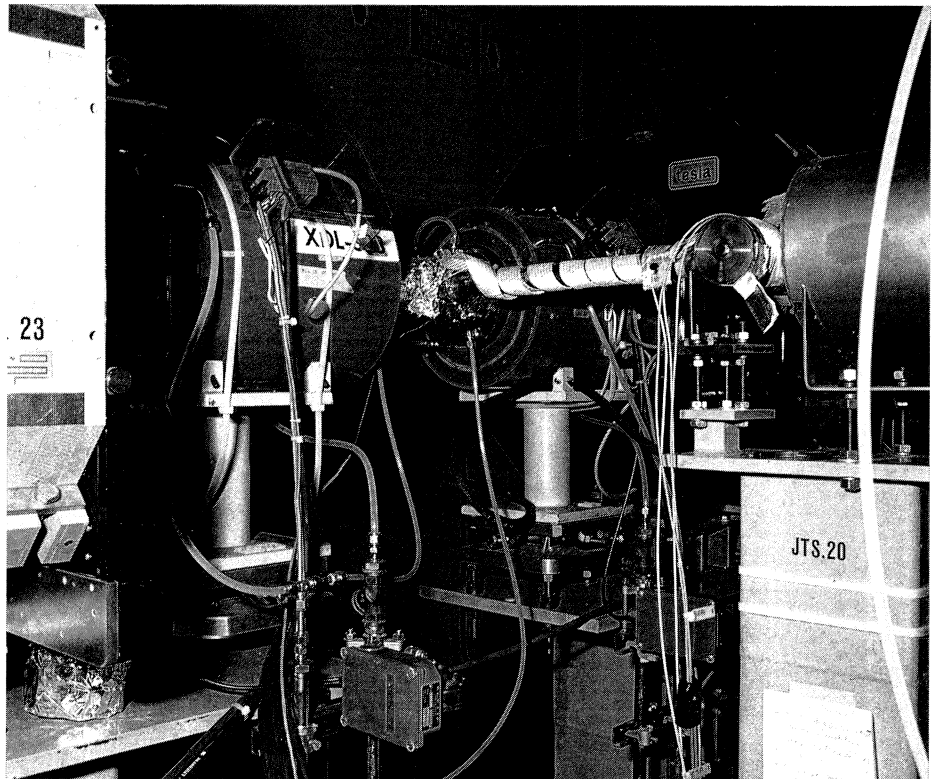

honorary Doctor of Science degree at the University of London on 12 October.

CERN theorist Maurice Jacob has been elected Foreign Member of the Royal Swedish Academy of Sciences.

CEBAF orders from Europe

In a contract worth ten million dollars, 360 superconducting accelerating cavities for the CEBAF Continuous Electron Beam Accelerator Facility, now under construction at Newport News, Virginia, have been ordered from the West German firm of Interatom.

Meetings

Neutrino '90, the 14th International Conference on Neutrino Physics and Astrophysics, will be held at CERN from 10-15 June. Participation is by invitation only. Further information from Neutrino '90 Secretariat, c/o Susan Maio, CERN/DG, 1211 Geneva 23, Switzerland, telephone Geneva 767 4687, fax Geneva 782 0168, e-mail neutrino at cernvm.cern.ch.

The Division of Particles and Fields of the American Physical Society will host another summer study in Snowmass, Colorado, from June 25 to July 13, entitled 'Research Directions for the Decade - 1990 DPF Summer Study on High Energy Physics' to examine all important scientific issues and opportunities in high energy physics, including

CERN Accelerator School goes north

In September in Uppsala, CERN's Accelerator School (CAS) organized its third Advanced Accelerator Course, this time in conjunction with Uppsala University. After a mainly theoretical first week, attention turned in the second week to specialized topics important in small rings – cooling techniques, internal targets, interactions with residual gas, ion trapping, intensity limitations, very cold beams, crystalline beams, etc. It was clear that, at least in the context of accelerators, 'small' does not mean 'less complex'. Visits to the Uppsala installations, including the Celsius cooler/storage ring, now operational (June, page 24), the Cryring storage ring for highly charged heavy ions, now under construction, and the laboratories of manufacturer Scanditronix testified to the vigour of this area of Swedish science.

For next year, CAS is offering a course on Power Converters for Particle Accelerators from 26-30 March in Montreux, Switzerland, and on General Accelerator Physics from 17-28 September at and in conjunction with KFA Jülich. Further information from Mrs. S. von Wartburg, CERN Accelerator School, CERN, 1211 Geneva 23, Switzerland, or by e-mail from caspower at cernvm.cern.ch or caskfa at cernvm.cern.ch respectively.



The CERN Accelerator School's course on Advanced Accelerator Physics was held in September at and in conjunction with Uppsala University, Sweden.

collider, fixed-target and non-accelerator experiments, accelerator and detector initiatives, and B factories. The physics and associated detector developments of the SSC and the LHC will be emphasized. Chairman of the Scientific Organizing Committee is Edmond L. Berger of Argonne (ELB at ANLHEP), and Conference Secretary is Robin Craven of Wisconsin (CRAVEN at WISCPSLB).

A workshop on beam dynamics issues of high luminosity asymmetric collider rings will be held at Berkeley from 12-16 February. Topics will be more general than the beam-beam interaction (although this will receive major attention), and would include coupled bunch effects, impedances, wakes, etc. It is hoped to establish conservative design criteria for these machines. Further information from the Conference Chairman, Andrew M. Sessler at Berkeley, bitnet tbalbl at lbl or fax (415) 486-5172.

ABB Mannheim leaves superconducting magnet production

The 223 nine-metre superconducting dipoles (half of the total required) for the HERA electron-proton collider being built at the German DESY Laboratory in Hamburg will be the last superconducting magnets to be built by Asea Brown Boveri (ABB) of Mannheim. The other half of the HERA dipole consignment is being supplied by an Italian consortium (LMI-Europame-talli for the cable, Ansaldo for the collared coils and Zanon for the cryostats).

Good Laboratory eating

Retiring as Chairman of the Users' Organization for the US Superconducting Supercollider (SSC) to be built in Texas, Lee Pondrom of Wisconsin joked that, with no cafeteria to complain about, prospective SSC users had to discuss something else.

The CERN itinerant exhibition stayed almost at home in October when it featured at the 'Foire du Valais' in the Swiss town of Martigny. The Fair attracted over 120,000 visitors during its ten days, and, as 'guest of honour', the CERN stand received a lot of attention. The CERN exhibition team has had another busy year, with eleven exhibitions of CERN's work spread around the Member States.

An operational Laboratory where cafeteria complaints should be rare, if its track record is anything to go by, is the Swiss Paul Scherrer Institute (PSI, formally SIN), Villigen. Over the past few years, its 'Oase' (Oasis) restaurant has amassed a whole pantry of culinary awards – silver and gold medals in two hotel and restaurant competitions in Germany this year, silver (art culinaire international) and gold (restauration collective) medals at the 2nd Salon Culinaire Mondial in Basle, Switzerland, in November 1987, a silver medal at the international culinary fair in Frankfurt, October 1988, a diploma in a Swiss national gastronomy fair in April 1987, and a gold medal at a similar event this April.

The 'Oase' serves an average of 530 lunches each working day to a total PSI staff of about 1100. Enthusiastic clients report that the menu is varied attractively with the season (fish, seafood, game), with additional variety coming from frequent national weeks, featuring menus from France, Italy, Spain, etc. The restaurant also provides catering services and has its own patisserie.

CERN 'Yellow' Reports 1989

The following reports have been published so far in 1989 in the official CERN Reports series:

CERN 89-01; Turner, S. (ed); Proceedings, CAS – CERN Accelerator School : Advanced accelerator physics, Berlin (West), 14 – 25 Sept. 1987, CERN, 20 Febr. 1989, – 276 p.

CERN 89-02; Schopper, H.; The evolution of CERN between 1981 and 1988 ; a status report presented by the Director-General to the CERN Council in December 1988 CERN, 20 Febr. 1989, – 38 p.



CERN 89-03; Dattoli, G; Torre, A; Free-electron laser theory, CERN, 1 March 1989. – 64 p.

CERN 89-04; Turner, S. (ed); Proceedings : CAS – CERN Accelerator School ; superconductivity in particle accelerators, Hamburg, 30 May – 3 June 1988, CERN, 10 March 1989, – 332 p.

CERN 89-05; Turner, S. (ed); Proceedings, CAS – CERN Accelerator School ; General accelerator physics, Salamanca, 19 – 30 Sept. 1988, CERN, 20 April 1989, – 250 p.

CERN 89-06; Verkerk, C. (ed); Proceedings, 1988 CERN School of Computing, Oxford, 15 – 26 August 1988, CERN, 25 April 1989, – 473 p.

CERN 89-07; Germain, P.; Dekkers, D. (ed); Introduction aux accélérateurs de particules. CERN, 7 July 1989. – 116 p.

CERN 89-08 (Vol. 1); Altarelli, G.; Kleiss, R.; Verzegnassi, C. (eds); Z physics at LEP 1 ; 1, Standard Physics; CERN, 21 Sept. 1989, – 456 p.

CERN 89-08 (Vol. 2); Altarelli, G.; Kleiss, R.; Verzegnassi, C. (eds); Z physics at LEP 1 ; 2, Higgs search and new physics; CERN, 21 Sept. 1989, – 214 p.

CERN 89-08 (Vol. 3); Altarelli, G.; Kleiss, R.; Verzegnassi, C. (eds); Z physics at LEP 1 ; 3, event generators and software, CERN, 21 Sept. 1989, – 343 p.

Copies may be obtained, while stocks last, from : Scientific Information Service, CERN, CH-1211 Geneva 23, Switzerland, or by e-mail to LIBDESK at CERNVM.CERN.CH

SCINTILLATION DETECTORS 'OFF THE SHELF'



Mounted crystals and complete assemblies for x-ray and gamma ray detection.

- Materials include NaI (TI), CsI(Tl), ZnWO₄BGO etc.
- Standard sizes from stock.
- Range of sizes and configurations.
- Laboratory and industrial applications.
- Specials to order.

Hilger Analytical Limited
Westwood Margate Kent CT9 4JL
Tel: 0843 225131 Fax: 0843 224402 Telex: 96252

 **HILGER**
Analytical

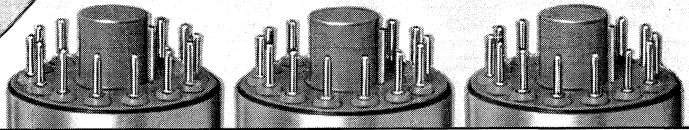

PARTICLE DETECTORS

- Streamer tubes chambers
- Read out strips
- Portable modules for teaching purposes (made of streamer tubes chambers, H.V. System, read out system and traces visualization)

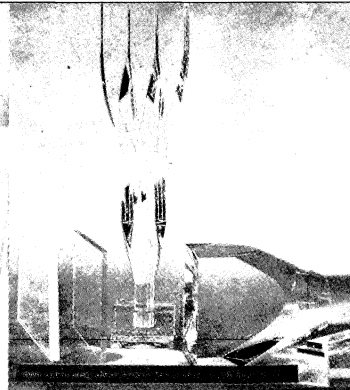

- Acrylic scintillators and light guides
- W.L.S.

pol. hi. tech. s.r.l.

S. p. Turanense ; Km 44,400 ; 67061 Carsoli (AQ) - Italy
Tel. (0863) 99 77 98/99 56 03 - Telefax (0863) 99 58 68

FASTBUS

DATALINE™



32-bit
High-speed
GPP

Features

- high-speed microprocessor with floating point coprocessor
- 1 Mbyte static RAM, upgradable to 16 byte dynamic RAM
- 1.5 Mbyte PROM, expandable to 4 Mbyte
- front-panel Ethernet and Cheapernet port
- SCSI bus for disk and tape drives
- Dual RS-232C serial ports
- Microprocessor expansion port on rear auxiliary connector
- OS-9, realtime, UNIX-like operating system
- Full FASTBUS Master/Slave capability
- User-programmable NIM level I/O on front-panel LEMO connectors

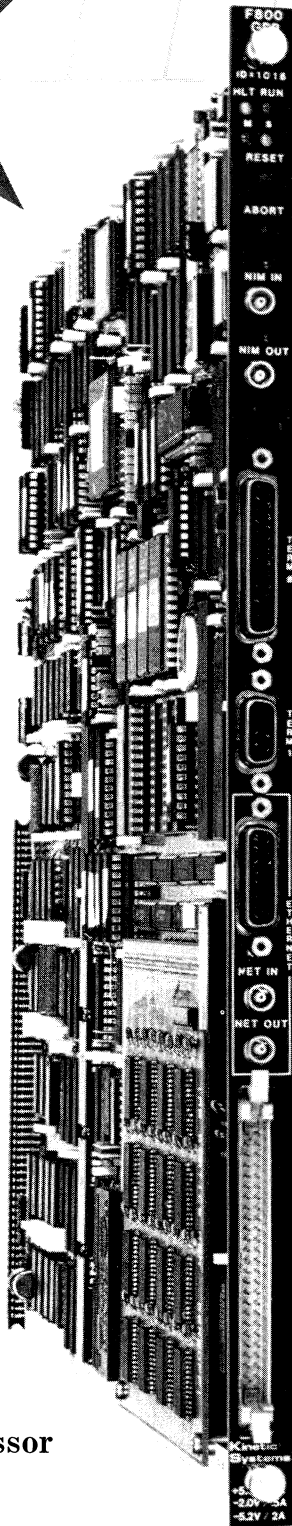

F800
General Purpose Processor

A new general purpose processor with realtime processing power

The new **F800** module is a general purpose processor (GPP) which serves as a primary host in small FASTBUS systems using an OS-9, realtime, UNIX-like operating system. As your FASTBUS system grows, any number of F800s may be installed for additional processing power.

This module contains a high-speed Motorola 68020 microprocessor and a 68881 floating point coprocessor with a full 32-bit data path. Providing the 68020 signals at the auxiliary connector for future expansion purposes permits the F800 to be easily interfaced to such other devices as bulk memory and graphic controllers as well as other buses. A front-panel SCSI (Small Computer System Interface) bus permits this module to boot up from a variety of disk and tape drives and to be used in data logging and file storage. Up to eight SCSI devices are permitted on this port (including itself).

The F800 GPP offers full FASTBUS Master/Slave capability. It provides block transfer rates of up to 20 megabytes per second as a slave device and up to 6 megabytes/second as a master. As a slave, this GPP supports geographic addressing as well as random and block transfer data cycles. Service requests and user interrupts are also supported.

Other features of the F800 include a one-megabyte static memory, provided on a daughter card. This memory is upgradable to 16 bytes of dynamic RAM and is accessible from both FASTBUS and the microprocessor. Dual RS-232 serial ports, located on the front panel, provide multiuser support or a simple link to the host processor. Baud rate is programmable from 300-38.4K Baud. Added flexibility on the RS-232 ports is provided by a 25-pin and a 9-pin connector.

F800 processors can be networked from a front-panel, P.C. board-selectable, Ethernet and Cheapernet port. The Ethernet port uses a standard, front-panel, 15-pin D-connector, and the Cheapernet requires LEMO type connectors.

Contact Us Now For More Information

Kinetic Systems International S.A. Europe

HOME OFFICE

3 chemin Taverney
LeGrand-Saconnex
CH-1218 GENEVE, Suisse
Tel: 22 798 4445
FAX: 22 798 05 25

GERMANY

Mozartstrasse 21
D-7800 Freiburg
West Germany
Tel: 761 33 265
FAX: 761 232 46

U.S.A.

11 Maryknoll Drive
Lockport, Illinois 60441
Tel: (815) 838 0005
TWX: 910 638 2831
FAX: (815) 838 4424

It's about TIME . . .

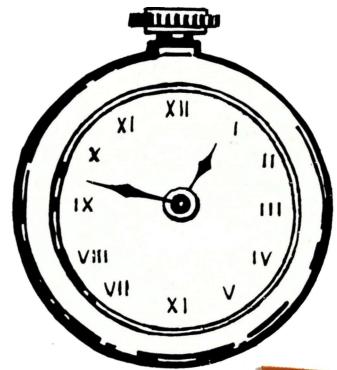

CAMAC Control of Constant-Fraction Timing

The **ALL NEW** CAMAC CCF8200 from EG&G ORTEC overcomes the timing limitations of leading-edge discriminators and offers **UNIQUE** benefits . . .

- Eight CFD channels with computer control in a CAMAC module
- An efficient solution for multi-detector experiments with Ge, Si, or scintillation detectors
- Individually programmable threshold settings
- Programmable output widths with programmable output masks
- Automatic walk adjustment
- Internally-selected shaping delay that eliminates bulky external cabling

For further convenience in multiple-detector experiments, there are two sets of ECL outputs, a Multiplicity output, an OR output, an Inhibit input, and a Test input.

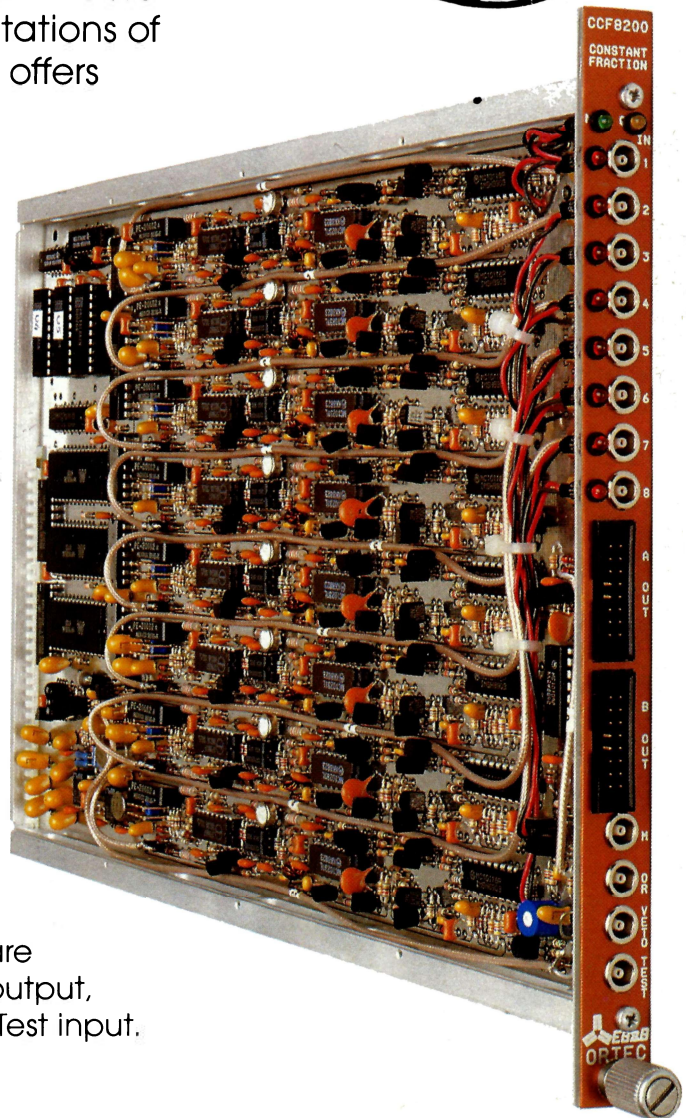

It's what you've been waiting for!

Save time by calling the **HOTLINE, 800-251-9750**, in the U.S.A. or contact your area EG&G ORTEC representative.



100 Midland Road, Oak Ridge, TN 37831-0895 U.S.A. • (615) 482-4411 • Telex 6843140 EGGOKRE • Fax (615) 483-0396

CANADA
(416) 475-8420

FRANCE
(01) 60.77.93.66

WEST GERMANY
(089) 926920

ITALY
(02) 7610267 (03) 638-1506

JAPAN
THE NETHERLANDS
(030) 887520

UNITED KINGDOM
(0734) 773003

high quality and performance VMEbus boards

AT THE RIGHT PRICE



TVM-3032 MC68030 VME/VSB

- MC68030 / MC68882
- 4/16 Mbytes VME/VSB 3-ported RAM
- in/out block transfer and data broadcast over the VMEbus
- 16x4 VME/VSB mailboxes and extensive multiprocessing support
- on board EPROM/EEPROM
- uses VTC's VIC068 VME chip

SFR 4.270.—

TVM-580 32/64 Mb VME/VSB

- 32/64 Mb dual-ported DRAM over VME/VSB
- block transfer support
- 4/8/16 Mb versions available

SFR 29.940.—

TVM-760 VME/VSB high speed A/D

- 10 million 12 bit conversions/second
- block transfer over VSB

SFR 8.780.—

Tecint has the solutions for the most advanced applications at the right price. This means your budget can buy more boards than ever, without compromises.

Call or write for a copy of our catalog.

tecint

Tecint products are used
by most Italian INFNs and worldwide

Headquarters:
VIA GERMANIA, 13 - 37136 VERONA - ITALY
PHONE +39 45 8620183 - FAX +39 45 8620645

Tecint Rome:
PHONE 06 2814 720
FAX 06 2417 201

Tecint has offices in the main countries worldwide, including Switzerland, USA, Germany, England, France.
Please send an enquiry by fax to have the name of your nearest distributor.

FAX: +39 45 8620645

High Performance BaF₂ Scintillators

MERCK – the authorized source!

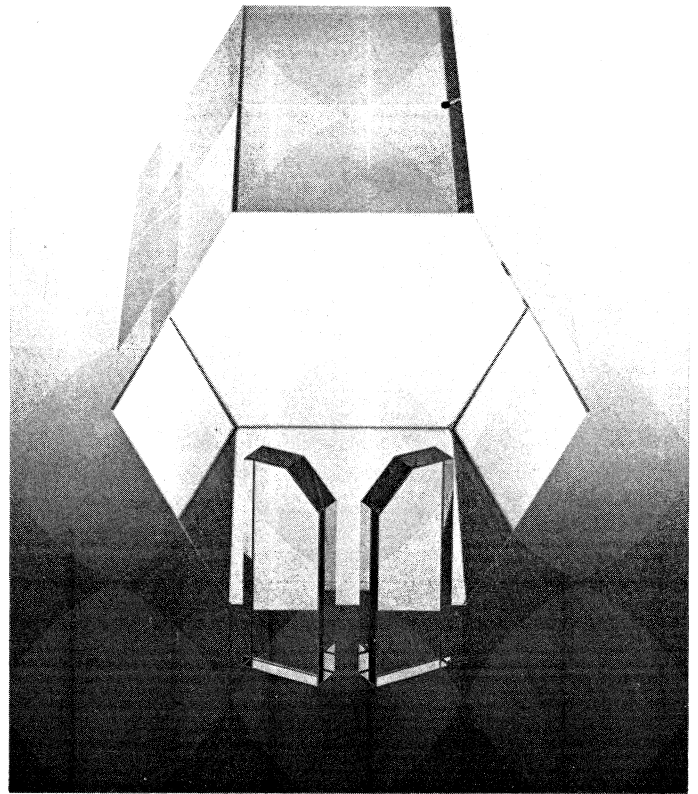

- High quality BaF₂ Scintillators produced under CEA* patents
- MERCK is also a reliable supplier for CsI, NaF, BGO and other materials of interest to you
- MERCK together with CRISMATEC is sole licensee for such BaF₂ Scintillators

For further information please contact E. Merck, Darmstadt

* Commissariat à l'Énergie Atomique, Paris, France

E. Merck
VIC ELO
P. O. Box 4119
D-6100 Darmstadt 1
Phone: (06151) 723686
Fax: (06151) 723630
Telex: 419328-0 emd

MERCK

Cryogenic Components

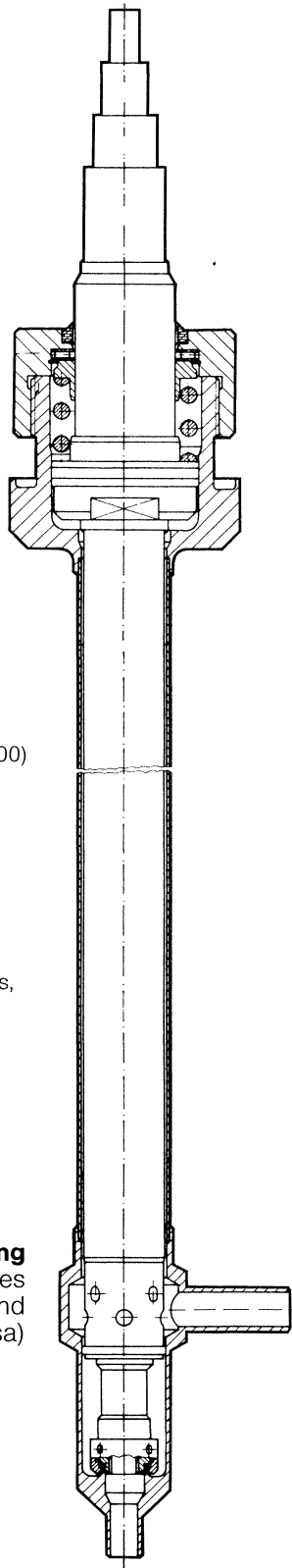

Manufacturing Line

- Cryogenic Valves
(Vacuum Jacketed and also for Cold Box Mounting, DN 2 - DN 100)
- Special Valves for Cryogenic Applications
(Check-Valves, Pilot Cryogenic Valves etc.)
- Bellows Sealed Valves
(DN 2 - DN 100, up to PN 300)
- Cryogenic Transferlines and Couplings
(Bayonet or Johnston Couplings, Multi-Coaxial Couplings)
- Space Cryogenic Fittings
- Tailor made Cryogenic Components e. g. Cryostats and Ejectors

Multi-Coaxial Coupling
for Cryogenic Transferlines
(LHe inlet and GHe outlet or vice versa)

for further informations:

WEKA AG

Hofstrasse 8, CH-8620 Wetzikon, Switzerland
Phone (0)1 932 23 02, Telex 875 744, Telefax (0)1 932 43 03

or in USA and Canada:

PROVAC LTD

POB 18411, Greensboro, North Carolina 27419
Phone (919) 282 6618, Telex 510 600 4853, Telefax (919) 288 3375

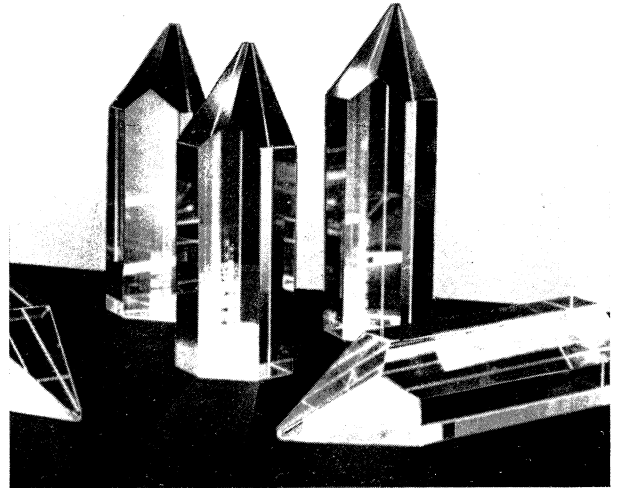

CORNING FRANCE

OPTICAL DIVISION DIVISION OPTIQUE

44, avenue de Valvins
77210 AVON - FRANCE
Tel.: 33-1 60 72 50 00
Telex: 690 562 CORFOPH
Fax: 33-1 60 72 18 30

The worldwide specialist in glasses for Cherenkov counters.

Le spécialiste mondial des verres pour compteurs Cherenkov.

LEWA

Hermetisch geschlossen
Kein Stopfbuchsärger
Keine Wartungsprobleme

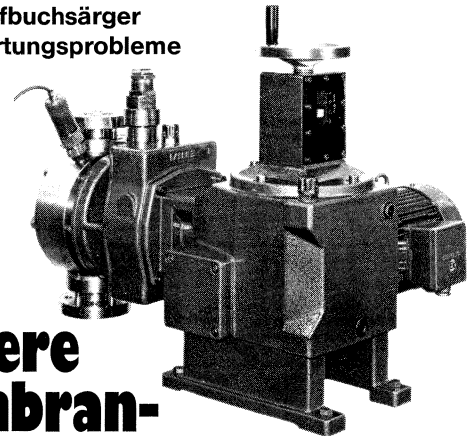

Die sichere Membran-Dosierpumpe

Für alle umweltgefährdenden, kritischen Fluide (übelriechende, giftige, radioaktive, aber auch sterile oder abrasive). In vielen Ausführungen für nahezu alle Betriebsanforderungen. Auch mit "Remote-Head". Förderströme von 5 ml/h bis über 100 m³/h, Drücke bis 3500 bar.

Mit der patentierten LEWA-Sandwichmembran bietet sie ein Höchstmaß an Betriebssicherheit.

Weitere Informationen: Broschüre D 2-200 bitte anfordern.

HERBERT OTT AG

Missionsstrasse 22, Postfach, CH-4003 Basel
Telefon 061/25 98 00, Telex 964 562 (hoc)